



Centrifugal Pump

Instruction Manual

• XCm • XNm • XGm • XSm
• XHm • XHSm • 2XCm • 3XCsm

LEO GROUP PUMP(ZHEJIANG) CO.,LTD.

Add: No.1,3rd Street, East Industry Center,317500
Wenling City, Zhejiang P.R.China

Tel: 0086-576-89986360

Fax: 0086-576-89989898

Email:export@leogroup.cn

www.leogroup.cn

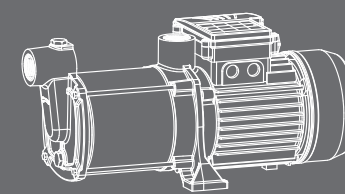
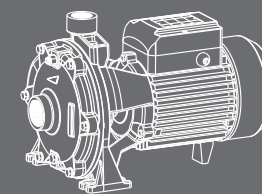
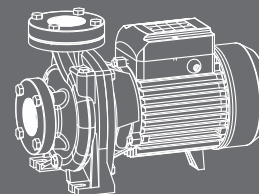

LEO GROUP PUMP(ZHEJIANG) CO.,LTD.

CONTENTS

1. Application Environment	2
2. Model Description	2
3. Technical	3
4. Implementation Standards	3
5. Safety Precautions	3
6. Product Structure	5
7. Pipeline Installation	6
8. Electrical Connection	8
9. Automatic Device	9
10. Start-up and Maintenance	10
11. Troubleshooting	11

Symptom	Cause	Corrective Action
Insufficient pressure	Incorrect pump type.	Select suitable pump.
	The inlet pipeline is too long or with too many bends, pipe diameter is not selected as required.	Apply the pipe with the stipulated diameter, and make the inlet pipe short.
	Inlet pipeline, filter screen or pump chamber is blocked by foreign materials.	Clean pipeline, foot valve or pump chamber, clear sundries.
The pump vibrates.	The pump is not fixed in the base.	Tighten the foundation bolt.
	There is sundries in the pipeline or pump chamber.	Check and clean the pipeline and pump body.
	The base is not enough stable.	Fix the pump on the stable base.
Motor works intermittently or the stator winding is burned out	The motor is in the overload operation for a long time.	Install the valve in outlet , reduce the water yield.
	The impeller is jammed or overload operation for a long time.	Clear sundries in the pump chamber; operate the pump under the rated flow as much as possible.
	Incorrect grounding, broken cable or the electric pump is hit by lightning.	Seek for the reason, and replace winding coils.
leakage of mechanical seal	The mechanical seal is worn and torn by impurities.	Clear or replace the mechanical seal.
Abnormal noise from the pump.	Noise from the bearing.	Replace with the same type bearing.
	Impeller is jammed.	Remove sundries.
	Excessive head.	Adjust to the range displayed on the nameplate before use.
Pressure switch do not work or start-stop too frequently	Pressure is too low inside the tank.	Check the pressure, and adjust it between 1.4-1.6bar
	Pressure is too high inside the tank.	

This appliance can be used by children aged from 8 years and above and persons with reduced physical, sensory or mental capabilities or lack of experience and knowledge if they have been given supervision or instruction concerning use of the appliance in a safe way and understand the hazards involved.

Children shall not play with the appliance. Cleaning and user maintenance shall not be made by children without supervision.

Attention!

If the appliance or the supply cord is damaged, it must be repaired by manufacturer, its service agent or qualified person.



Meaning of crossed –out wheeled dustbin:
Do not dispose of electrical appliances as unsorted municipal waste, use separate collection facilities.
Contact you local government for information regarding the collection systems available.



Before installation, you should carefully read this manual, and pay attention to safety cautions and instructions in this manual.

Manufacturer is neither responsible for nor is reliable for paying compensation for personal injury, pump damage and property losses caused by violation of safety cautions.

1. Application Environment

- 1). It is applicable to household water supply, equipment support, pipeline pressurization, garden watering and spraying, vegetable greenhouse watering, breeding, industrial and mining, water supply and drainage of enterprise and high-rise buildings, center air conditioner and centralized heating circulation system, etc..
- 2). Transfer clean water and other non-corrosive liquids with low viscosity; do not transport inflammable, explosive, gasified liquid and liquids containing solid particles or fibers. The liquid PH value shall be within 6.5-8.5.

2. Model Description

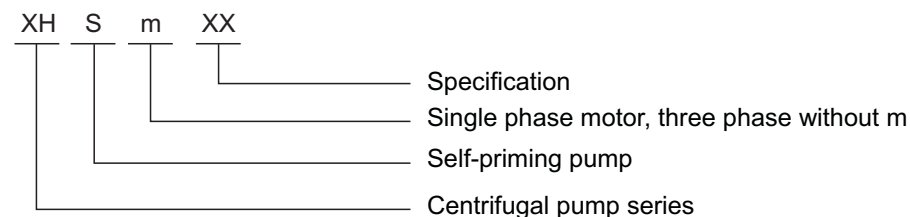
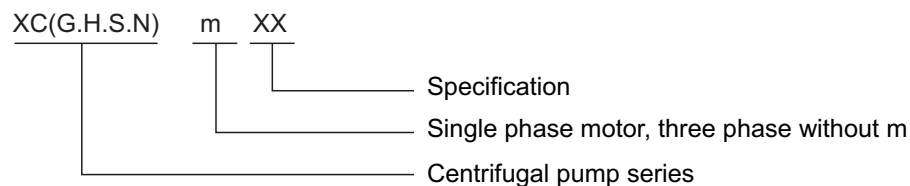

11. Troubleshooting



Check the pump after power cut-off.

Symptom	Cause	Corrective Action
The motor can not be started	Single-phase power supply (three-phase electric motor): a. poor connection of the power switch; b. fuse is burned out; c. loose power lead; d. phase failure of the cable	a. repair switch contact or replace the switch; b. replace the safety fuse; c. check and tighten the power connector; d. repair or replace cables.
	Capacitor is burned out.	Replace with a same type capacitor (send to the maintenance point for repair).
	The rotating shaft and bearing are jammed.	Replace the bearing (send to the maintenance point for repair).
	Impeller is jammed.	Turn rotating shaft of the fan blade terminal with screw driver to let it rotate flexibly or demount the pump body to clear sundries.
	Stator winding is damaged.	Replace winding coils (send to the maintenance point for repair).
	Pipe pressure above the setting pressure of pressure switch (automatic pump).	Increase power cut-off pressure of the pressure switch, namely, rotate the variable screw nut in “+” direction one or two round, or change with more suitable product.
The motor is in operation, but no water is discharged	Incorrect direction of pump rotation.	Invert two-phase wirings of the motor (three-phase motor).
	The pump is not fully filled with water.	Re-fill the pump with water.
	The impeller is damaged.	Replace the impeller (send to the maintenance point for repair).
	Leakage of the suction pipe.	Check sealing of various joints of the inlet pipelines.
	Water level is too low.	Adjust installation height of the pump.
	Freeze caused by accumulated water in the pipeline or the chamber.	Start up the pump after ice is melted.

10. Start-up and Maintenance



Do not switch on the pump if the pump chamber is not fully filled with water.
Do not touch the electric pump unless the power of pump is cut off for over 5 minutes.
Do not remove the pump bonnet unless the water in pump chamber is completely drained.

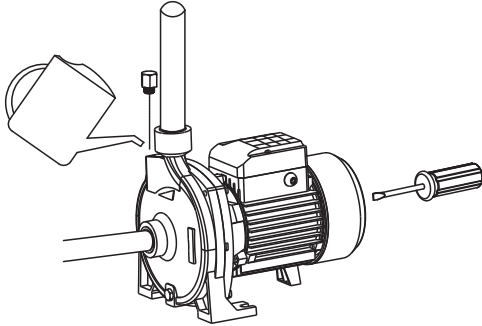

Stir the fan with a screwdriver to check if the pump rotates flexibly before startup. Remove the filling plug and prime the pump chamber fully with clean water, then screw the filling plug. Keep the valve wide opened during startup. When the pump runs normally, adjust the valve to the required flow (The range of flow and head is shown on the nameplate).

Note:

- 1). If no water can be pumped in 5 minutes after the pump is filled with water and started up, turn off and refill the pump, or check the leakage of inlet pipelines, then restart the pump.
- 2). For frost and freeze protection, remove the discharge plug on the air tank and drain the water in the pump chamber completely. Before restart the pump, it's necessary to remove the filling plug, fill the pump fully with water, and then screw the filling plug.
- 3). In case of no use for a long time, discharge the water in the pump chamber and store the pump in a dry, well-ventilated place.
- 4). If the ambient temperature is high, make sure the pump works in a well-ventilated place to avoid electrical faults caused by dew on electrical parts.
- 5). In case of overheat or abnormal operation of the pump motor, cut off the power supply immediately, and check the faults according to the following form.

3. Technical

Max. Flow: 1800 L/min

Max. Head: 75 m

Output Power: 0.25 ~ 11 kW

Max. Suction: 8 m

Insulation Class: IPX4

Protection Class: F

Max. Ambient Temperature: +40°C

Max. Liquid Temperature: +60°C

4. Implementation Standards

- IEC/EN 60335-1 Household and similar electrical appliances--safety Part1:General requirements.
- IEC/EN 60335-2-41 Household and similar electrical appliances--safety Part2-41:Particular requirements for pump.
- 2014/35/EU Low voltage directive

5. Safety Precautions

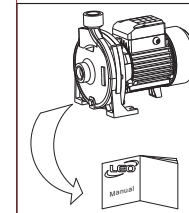

1. To ensure normal and safety operation of the electric pump, read the manual carefully before use.

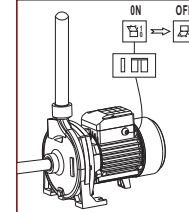

2. To avoid electric shock, make sure the pump is safely grounded and equipped with an earth leakage circuit breaker. Do not get the plug wet and do not use any socket in an area with high humidity.

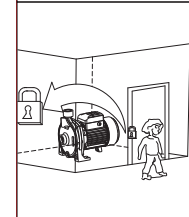

3. Do not touch the electric pump while working; do not wash, swim near working area or let livestock into the water to avoid accidents.

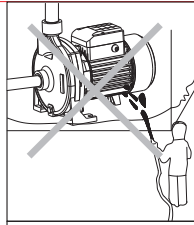

4. Avoid splashing pressured water to the electric pump
Do not immerse the pump in water.

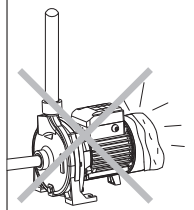

5. Keep the pump in a well-ventilated place.

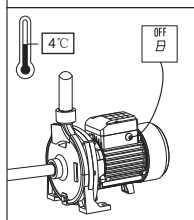

6. If the environment temperature is below 4°C or after long period of non-use, the liquid inside shall be discharged for freeze and frost protection.

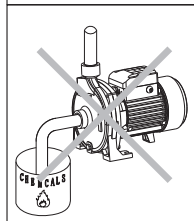

7. Never use the pump to transport inflammable, gasifying or explosive liquid that exceeds the specified liquids in this manual.

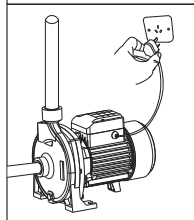

8. Ensure the pump will not be accidentally turned on while installing and maintaining; if not used for a long time, cut off the power first and then turn off valves in inlet and outlet of the pump.

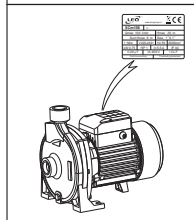

9. The power supply should be in accordance with the voltage stated in the nameplate. If the pump is not be used for a long time, empty it completely, wash it with clean water and store it in a dry, well-aired place.

9. Automatic Device

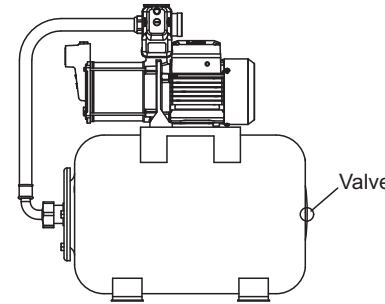

Figure 3 Automatic Device Diagram

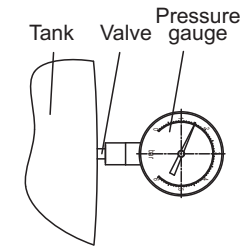

Figure 4

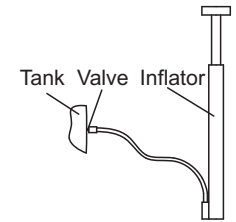

Figure 5

Once using the pump, check the tank pressure regularly according to figure 4. If the tank pressure is lower than 1.2bar, fill air to the tank with inflator or other air charging devices like figure 5. Pressure in the tank can not exceed 1.6 bar, and the ideal pressure is between 1.4 to 1.6 bar.

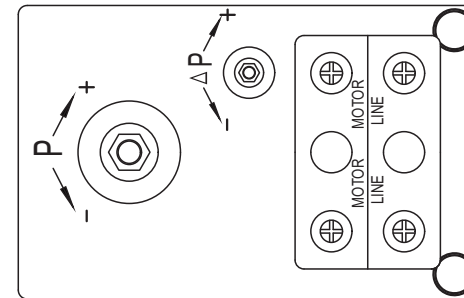

Figure 6 Pressure Switch Connection Diagram

- 1). While using the automatic pump, in case it still operates after turning off the water tap, lower down power cut-off pressure of the pressure switch, namely, rotate the variable screw nut "P" in "-" direction to acquire lower cut-in pressure.
- 2). In case the pump is often enabled when the water tap is turned off (sometimes it is turned on and sometimes it is turned off), check whether pipeline and the foot valve have leakages, eliminate timely if any.
- 3). In case the pressure switch is alternately turned on or turned off (frequent start) after turning on the water tap, increase power cut-off pressure of the pressure switch, namely, rotate the variable screw nut "P" in "+" direction to acquire higher cut-in pressure.

8. Electrical Connection



Make sure that there is no voltage at the line wire terminals before connecting.
The electric pump shall be grounded reliably to avoid electric leakage and an earth leakage circuit breaker shall be equipped.

The electrical connection shall be carried out according to the local regulations. Check that the pump operates within the specified range on the nameplate. Connect up the pump (making sure that there is an efficient grounding circuit) according to the diagram on the nameplate on the motor.

The correct direction of rotation for three-phase motors is clockwise, looking at the pump from the motor fan side. If this is not the case, invert two of the phases.

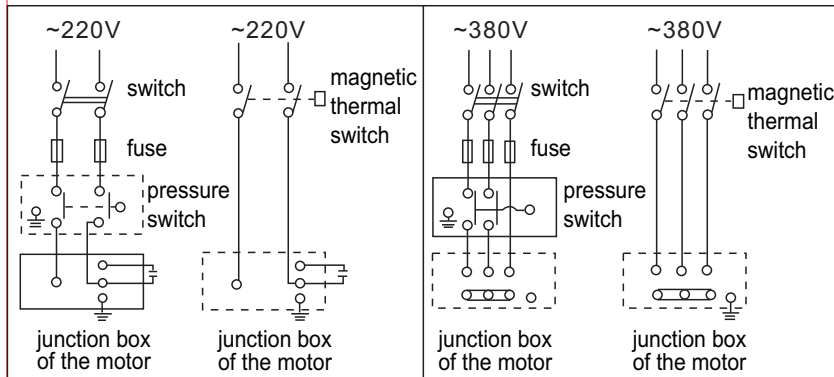
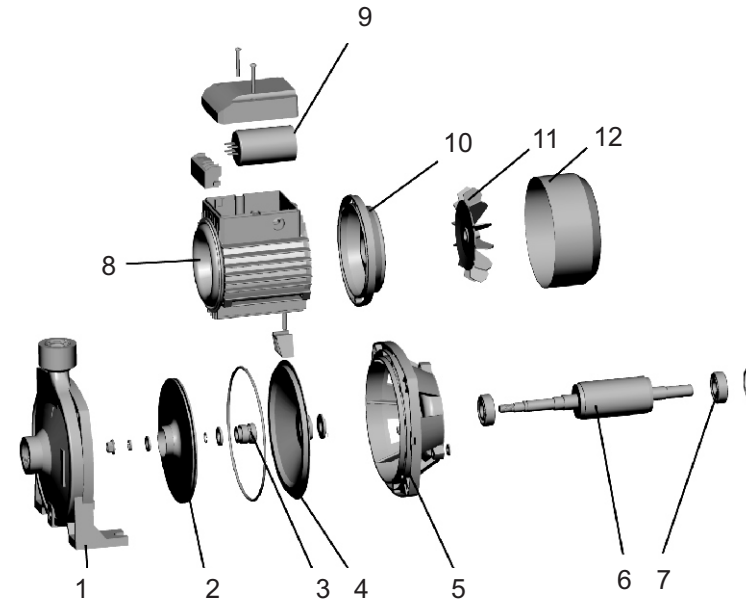

Figure 2 Electrical Connection Diagram

6. Product Structure



POS.	Part
1	Pump body
2	Impeller
3	Mechanical seal
4	Bracket cover
5	Support
6	Rotor

POS.	Part
7	Bearing
8	Stator
9	Capacitor
10	Rear cover
11	Fan
12	Fan cover

7. Pipeline Installation



This product shall be installed and maintained by a qualified person who is proficient with this instruction. The installation and operation must be in accordance with local regulations and the recognized operation criteria. Install the pipeline properly according to the requirement of this instruction, and protect it from freezing.

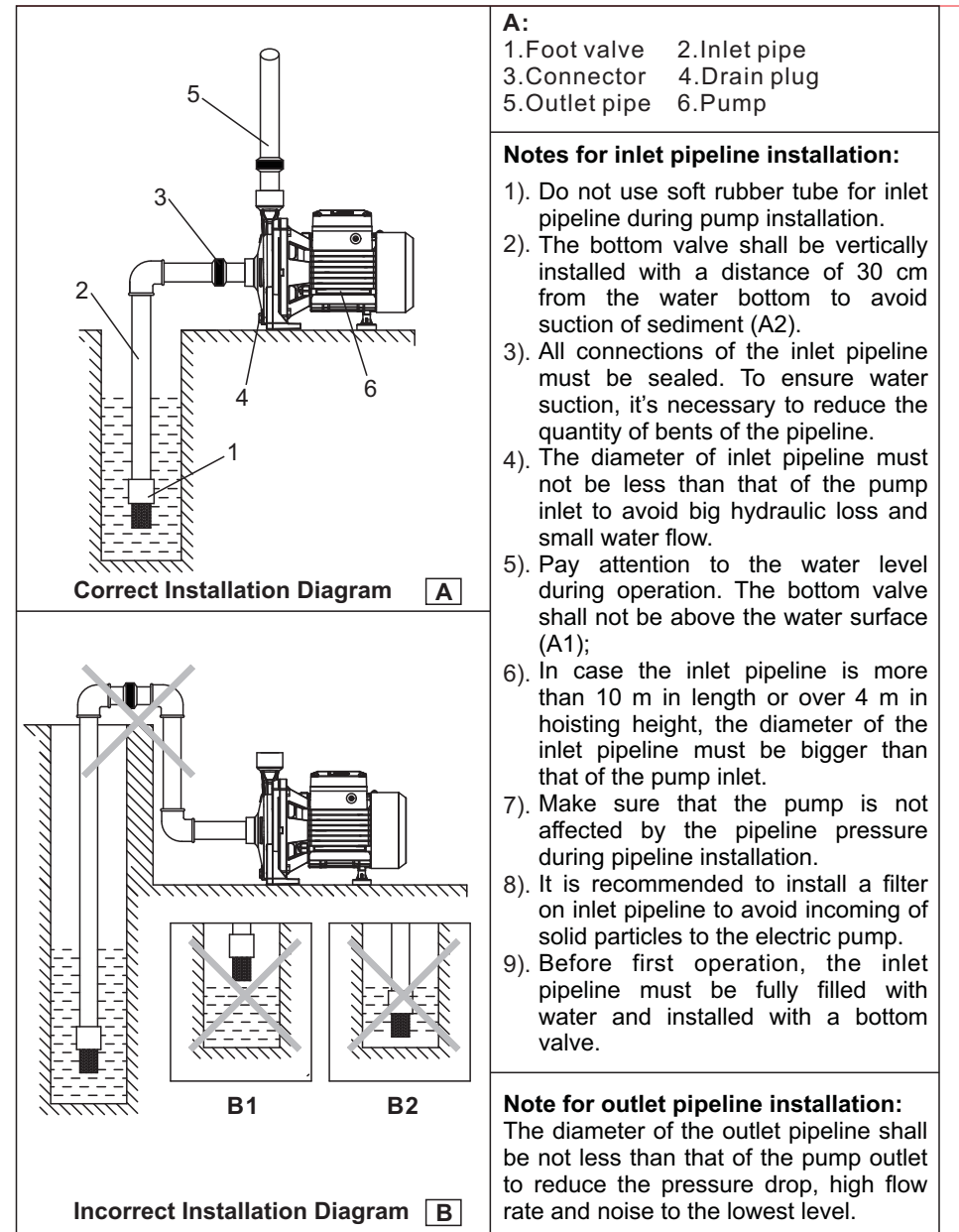
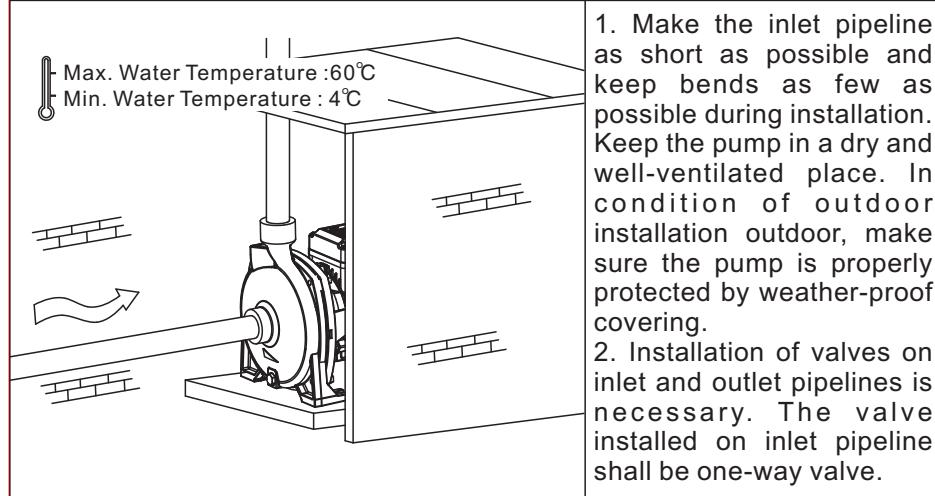

Figure 1 Pump Pipeline Installation Diagram