



Leo in the world

Asia

America

Europe

Oceania



**LEO GROUP PUMP(ZHEJIANG) CO.,LTD.**

Add: No.1,3rd Street, East Industry Center,317500  
Wenling City, Zhejiang P.R.China

Tel: 0086-576-89986360

Fax: 0086-576-89989898

Email:export@leogroup.cn

www.leogroup.cn

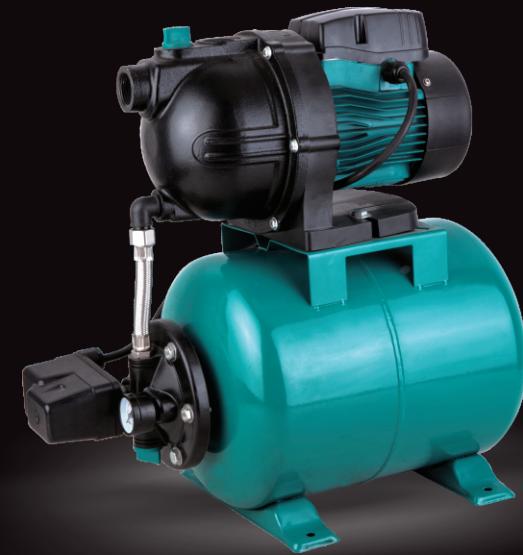

**PRESSURE BOOSTER SYSTEM**

**LKJ-A/EKJ-A**

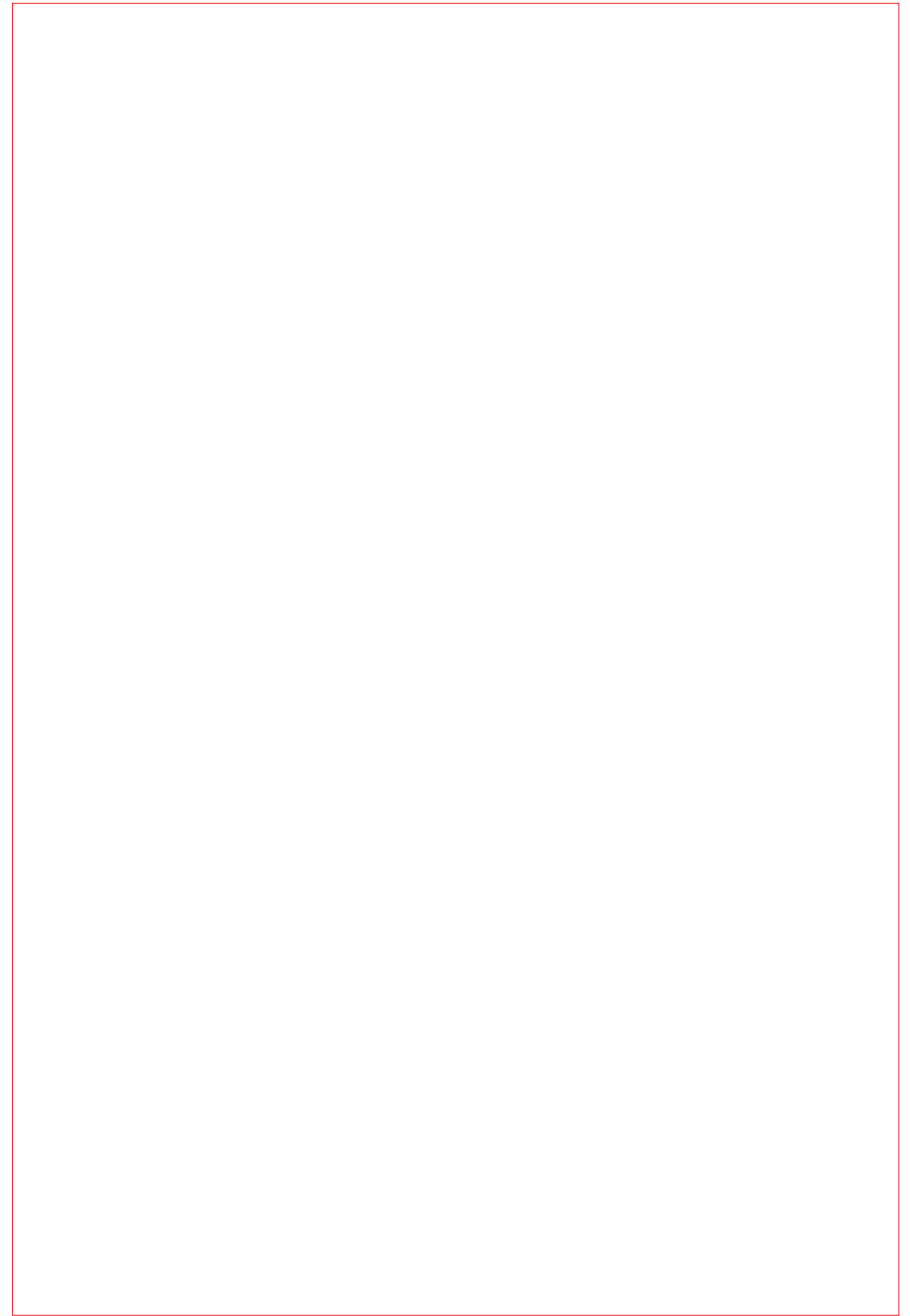

## CONTENTS

1. Applications .....	3
2. Model Description.....	3
3. Implementation Standards .....	4
4. Safety Precautions .....	4
5. Product Structure .....	6
6. Pipeline Installation .....	8
7. Start-up and Maintenance .....	10
8. Troubleshooting .....	11
9. Technical Data .....	12

# LKJ-A/EKJ-A

Pressure Booster System

This appliance can be used by children aged from 8 years and above and persons with reduced physical, sensory or mental capabilities or lack of experience and knowledge if they have been given supervision or instruction concerning use of the appliance in a safe way and understand the hazards involved.

Children shall not play with the appliance. Cleaning and user maintenance shall not be made by children without supervision.

## Attention!

If the appliance or the supply cord is damaged, it must be repaired by manufacturer, its service agent or qualified person.



Meaning of crossed –out wheeled dustbin:  
Do not dispose of electrical appliances as unsorted municipal waste, use separate collection facilities.  
Contact you local government for information regarding the collection systems available.



EKJ-602PA/EKJ-802PA

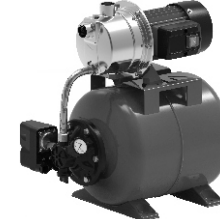

EKJ-602SA/EKJ-802SA



EKJ-602IA/EKJ-802IA

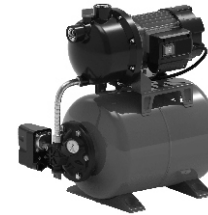















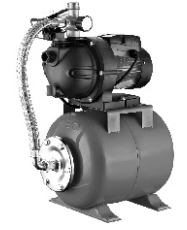

EKJ-1002PA/EKJ-1202PA



EKJ-1002SA/EKJ-1202SA



EKJ-1002IA/EKJ-1202IA

			
LKJ-00PA	LKJ-01PA	LKJ-00SA	LKJ-01SA
			
LKJ-00IA	LKJ-01IA	LKJ-00PA5	LKJ-01PA5
			
LKJ-00SA5	LKJ-01SA5	LKJ-00IA5	LKJ-01IA5
			
LKJ-00PSA5	LKJ-01PSA5	LKJ-00SSA5	LKJ-01SSA5



Read the instructions carefully and follow the rules for safe operation.  
The operator shall take full responsibility for personal injury, pump damage and other property losses caused by violation of safety cautions.

## 1. Applications

It is applicable to household water supply, equipment support, well water lifting, pipeline pressurization, garden watering, vegetable greenhouse watering, fish farming and poultry raising, etc..

Transfer clean water and other non-corrosive liquids with low viscosity; do not transport inflammable, explosive, gasified liquids and liquids containing solid particles or fibers. The PH of water must be between 6.5 and 8.5.

### Remark:

This series of pump could be transformed into automatic water pump, which is realized through external automatic plant that is composed of pressure switch, pressure tank, etc.. Function features of the automatic pump are as follows: when the power is on, turn on the water tap and the pump will start working automatically; when the water tap is turned off, the pump will stop working automatically. If a water tower is used along with the automatic pump, connect to the upper limit switch and the pump will start or stop working automatically with water level in the water tower.

## 2. Model Description

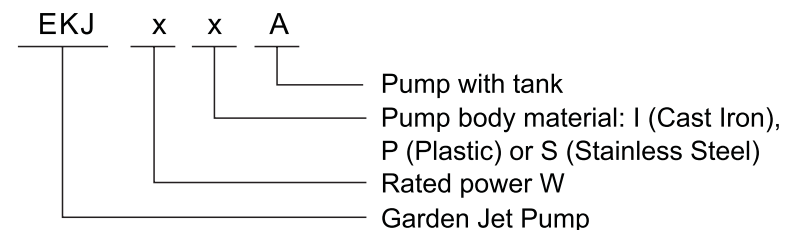
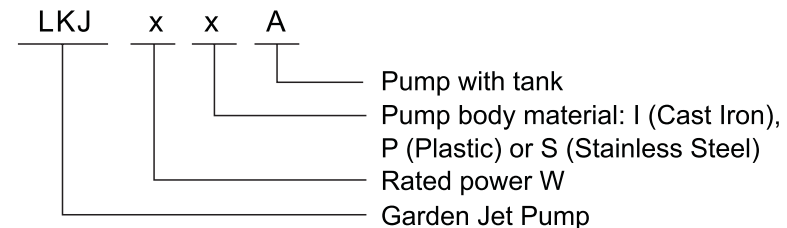

### 3. Implementation Standards

IEC/EN 60335-1 Household and similar electrical appliances--safety Part1: General requirements.

IEC/EN 60335-2-41 Household and similar electrical appliances--safety Part2-41:Particular requirements for pump.

2014/35/EU Low voltage directive

### 4. Safety Precautions

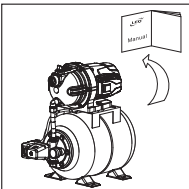

1).To ensure normal and safety operation of the electric pump, read the manual carefully before use.

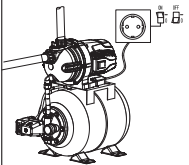

2).The electric pump should have reliable grounding to prevent short circuit; for safety, leakage protection switch should be equipped and be careful no to wet the power plug; socket should be connected in damp - proof area.

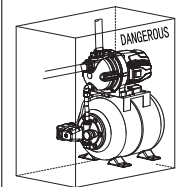

3).Do not touch the electric pump while working; do not wash, swim near working area or let livestock into the water to avoid accidents.

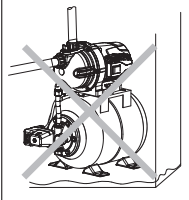

4).Avoid splashing pressured water to the electric pump as well as prevent the pump immersed by water.

Type	Plastic Jet Pump			
Model	EKJ-602PA	EKJ-802PA	EKJ-1002PA	EKJ-1202PA
Voltage	220-240V	220-240V	220-240V	220-240V
Frequency	50Hz	50Hz	50Hz	50Hz
Rated Power	600W	800W	1000W	1200W
Max.Head	35m	40m	45m	50m
Max.Flow	3.0m <sup>3</sup> /h	3.7m <sup>3</sup> /h	4.5m <sup>3</sup> /h	5.0m <sup>3</sup> /h
Max.Suction Depth	7m	7m	8m	8m
Outlet/Inlet	1"*1"	1"*1"	1"*1"	1"*1"
Electric Protection Class	IPX4	IPX4	IPX4	IPX4
Max.liquid temperature	35°C	35°C	35°C	35°C

Type	Cast Iron Jet Pump			
Model	EKJ-602IA	EKJ-802IA	EKJ-1002IA	EKJ-1202IA
Voltage	220-240V	220-240V	220-240V	220-240V
Frequency	50Hz	50Hz	50Hz	50Hz
Rated Power	600W	800W	1000W	1200W
Max.Head	35m	40m	45m	50m
Max.Flow	3.0m <sup>3</sup> /h	3.7m <sup>3</sup> /h	4.5m <sup>3</sup> /h	5.0m <sup>3</sup> /h
Max.Suction Depth	7m	7m	8m	8m
Outlet/Inlet	1"*1"	1"*1"	1"*1"	1"*1"
Electric Protection Class	IPX4	IPX4	IPX4	IPX4
Max.liquid temperature	35°C	35°C	35°C	35°C

Type	Stainless Steel Jet Pump			
Model	EKJ-602SA	EKJ-802SA	EKJ-1002SA	EKJ-1202SA
Voltage	220-240V	220-240V	220-240V	220-240V
Frequency	50Hz	50Hz	50Hz	50Hz
Rated Power	600W	800W	1000W	1200W
Max.Head	35m	40m	45m	50m
Max.Flow	3.0m <sup>3</sup> /h	3.7m <sup>3</sup> /h	4.5m <sup>3</sup> /h	5.0m <sup>3</sup> /h
Max.Suction Depth	7m	7m	8m	8m
Outlet/Inlet	1"*1"	1"*1"	1"*1"	1"*1"
Electric Protection Class	IPX4	IPX4	IPX4	IPX4
Max.liquid temperature	35°C	35°C	35°C	35°C

**9. Technical Data**

Type	Pressure Booster System	
Model	LKJ-600PA/IA/SA/PA5/IA5/SA5/PSA5/SSA5	LKJ-800PA/IA/SA/PA5/IA5/SA5/PSA5/SSA5
	LKJ-601PA/IA/SA/PA5/IA5/SA5/PSA5/SSA5	LKJ-801PA/IA/SA/PA5/IA5/SA5/PSA5/SSA5
Rated Power	600W	800W
Max. Head	35m	40m
Max. Flow	3.6m <sup>3</sup> /h	3.6m <sup>3</sup> /h
Outlet/Inlet	G1×G1	G1×G1
Protection Class	IPX4	IPX4
Opening Pressure	1.4bar	1.4bar
Shutoff Pressure	2.4bar	2.8bar
Operating Limits	Fluid temperature up to 35°C; Ambient temperature up to 40°C.	

Type	Pressure Booster System	
Model	LKJ-900PA/IA/SA/PA5/IA5/SA5/PSA5/SSA5	LKJ-1100PA/IA/SA/PA5/IA5/SA5/PSA5/SSA5
	LKJ-901PA/IA/SA/PA5/IA5/SA5/PSA5/SSA5	LKJ-1101PA/IA/SA/PA5/IA5/SA5/PSA5/SSA5
Rated Power	900W	1100W
Max. Head	43m	46m
Max. Flow	3.6m <sup>3</sup> /h	4.6m <sup>3</sup> /h
Outlet/Inlet	G1×G1	G1×G1
Protection Class	IPX4	IPX4
Opening Pressure	1.4bar	1.4bar
Shutoff Pressure	2.8bar	2.8bar
Operating Limits	Fluid temperature up to 35°C; Ambient temperature up to 40°C.	

Type	Pressure Booster System	
Model	LKJ-1300PA/IA/SA/PA5/IA5/SA5/PSA5/SSA5	
	LKJ-1301PA/IA/SA/PA5/IA5/SA5/PSA5/SSA5	
Rated Power	1300W	
Max. Head	48m	
Max. Flow	5.0m <sup>3</sup> /h	
Outlet/Inlet	G1×G1	
Protection Class	IPX4	
Opening Pressure	1.8bar	
Shutoff Pressure	3.2bar	
Operating Limits	Fluid temperature up to 35°C; Ambient temperature up to 40°C.	

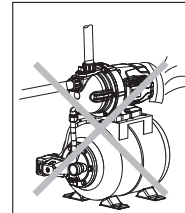

5).Keep the pump in ventilation.

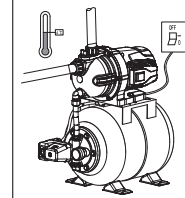

6).In case ambient temperature is lower than 4°C or the pump is not used for a long time, empty liquid the pipeline system to avoid ice cracking of the pump chamber. Do not keep the pump dry running for a long time.

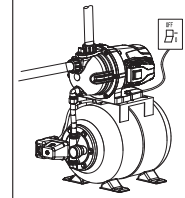

7).The pumped liquid may be hot and under high pressure. Before moving and demounting the bump, valves in both sides of the bump should be turned off first and then empty liquids in the pump and pipelines so as not to be scalded.

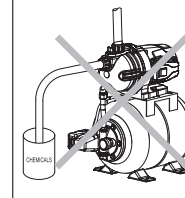

8).Do not transfer any inflammable, explosive or gasified liquids that beyond the stipulation.

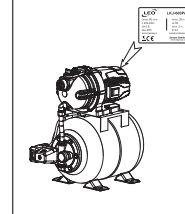

9).Power supply should be in accordance with the voltage stated in the nameplate. Keep the pump in a dry, well ventilated and cool place under room temperature for long time storage.

### 5. Product Structure

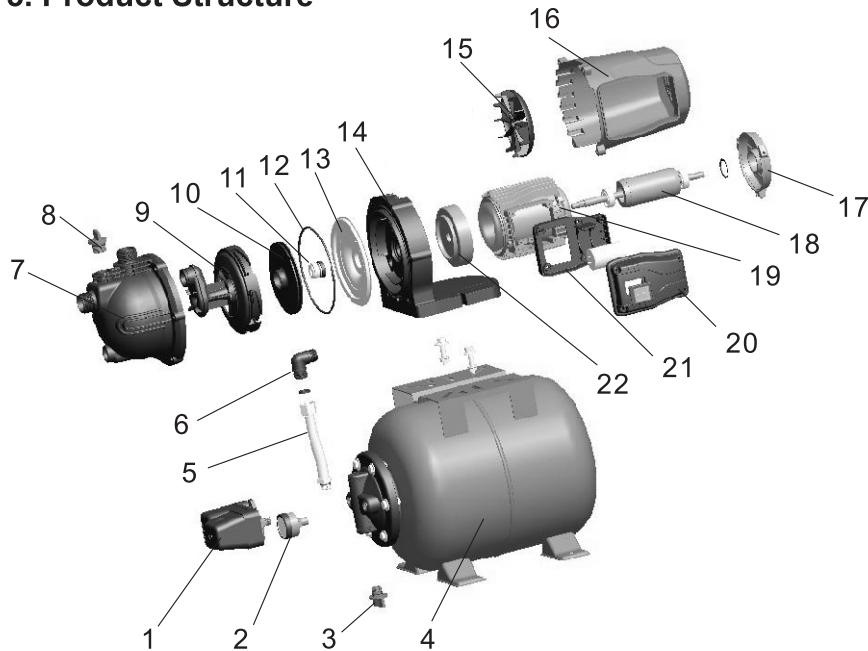

POS.	Part
1	Pressure switch
2	Pressure gauge
3	Drain plug
4	Tank
5	Flexible hose
6	Elbow connector
7	Pump body
8	Filling plug
9	Diffuser
10	Impeller
11	Mechanical seal

POS.	Part
12	O-ring
13	Bracker cover
14	Motor flange
15	Fan
16	Motor cover
17	End plate
18	Rotor
19	Stator
20	Switch cover
21	Terminal board
22	Front plate

### 8. Troubleshooting



Check the pump after power cut-off.

Symptom	Cause	Corrective Action
The motor can not be started	Single-phase power supply (three-phase electric motor): a. poor connection of the power switch; b. fuse is burned out; c. loose power lead; d. phase failure of the cable.	a. repair switch contact or replace the switch; b. replace the safety fuse; c. check and tighten the power connector; d. repair or replace cables.
	Capacitor is burned out.	Replace with a same type capacitor (send to the maintenance point for repair).
	The rotating shaft and bearing are jammed.	Replace the bearing (send to the maintenance point for repair).
	Impeller is jammed.	Turn rotating shaft of the fan blade terminal with screw driver to let it rotate flexibly or demount the pump body to clear sundries.
The motor is in operation, but no water is discharged	Stator winding is damaged.	Replace winding coils (send to the maintenance point for repair).
	Incorrect direction of pump rotation.	Invert two-phase wirings of the motor (three-phase motor).
	The pump is not fully filled with water.	Re-fill the pump with water.
	The impeller is damaged.	Replace the impeller (send to the maintenance point for repair).
	Leakage of the suction pipe.	Check sealing of various joints of the inlet pipelines.
	Water level is too low.	Adjust installation height of the pump.
	Freeze caused by accumulated water in the pipeline or the chamber.	Start up the pump after ice is melted.
Insufficient pressure	Water that is too hot can result in the failure of plastic parts.	Replace the damaged parts (send to the maintenance point for repair)
	Incorrect pump type.	Select suitable model.
	The inlet pipeline is too long or with too many bends, or/and pipe diameter is not selected as required.	Apply the pipe with the stipulated diameter, and make the inlet pipe short.
Motor works intermittently or the stator winding is burned out	Inlet pipeline, filter screen or pump chamber is blocked by foreign materials.	Clean pipeline, foot valve or pump chamber, clear foreign materials.
	The impeller is jammed or in overload operation for a long time.	Clear foreign materials in the pump chamber; operate the pump under the rated flow.
	Incorrect grounding, broken cable or the electric pump is struck by lightning.	Properly grounded, replace the broken cable, and replace winding coils.

## 7. Start-up and Maintenance



Do not start up the pump before the pump chamber is filled with water.  
Do not touch the electric pump unless its power has been cut off for at least 5 minutes.  
Do not dismount the pump body unless water in the pump chamber is emptied.

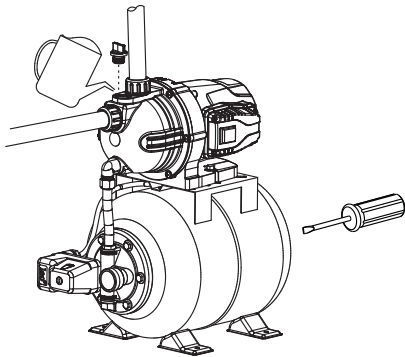

Rotate the fan blade before start-up, check whether the pump rotation is flexible and then unscrew the water-filling plug, fill the pump chamber with clean water from the water injection hole, then tighten the plug screw after the air has been completely discharged. Set the valve in a smaller flow in start-up and adjust to the required flow after water discharging (working range is displayed on the nameplate).

### Attention:

- 1). The pump chamber should be filled with water before first use and water refilling is unnecessary in the future.
- 2). In case no water is discharged after being started for more than 5 minutes with water filled, turn off the electric pump, re-fill water or check whether the inlet pipeline has leakages.
- 3). In case of any frost and ice damages, please open the drain plug to empty water in the pump chamber. When start up the pump again, open the drain plug, fill water and tighten it and then the pump is usable.  
In case not use for a long time, water in the pump should be emptied.
- 4). The pump body, impeller and support should be cleaned and coated with anticorrosive oil before they are put in a ventilated and dry place for use.
- 5). In case the pump is halted for a long time, start it up again according to above diagram.
- 6). In summer or when the ambient temperature is high, pay attention to ventilation, avoid dew on electrical parts which will result in electrical faults.
- 7). In case the motor is hot or abnormal, cut off the power immediately and check faults according to the following table.

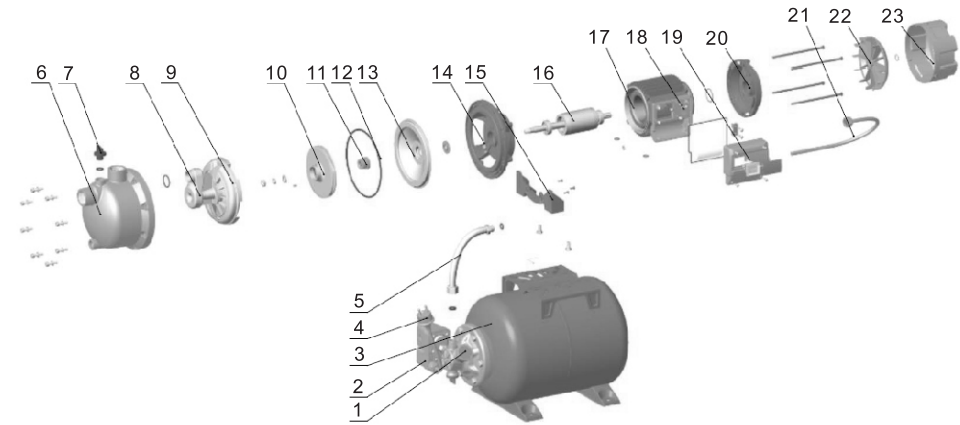

POS.	Part
1	Pressure Gauge
2	Pressure Switch
3	Pressure Tank
4	Cable
5	Flexible Hose
6	Pump Body
7	Inlet Plug
8	Ejector
9	Diffuser
10	Impeller
11	Mechanical Seal
12	O-ring

POS.	Part
13	Support Cover
14	Support
15	Stand
16	Rotor
17	Stator
18	Terminal Box
19	Terminal Cover
20	End Plate
21	Cable
22	Fan
23	Fan Cover

## 6. Pipeline Installation



This product should be installed and maintained by personnel who is proficient in this manual and has special qualifications. Installation and operation should be in accordance with local regulations and recognized operation standards. Install pipelines properly as stipulated in the manual and meanwhile conduct frost protection measures for the pipeline.

Max. Water Temperature :40°C  
Min. Water Temperature : 4°C

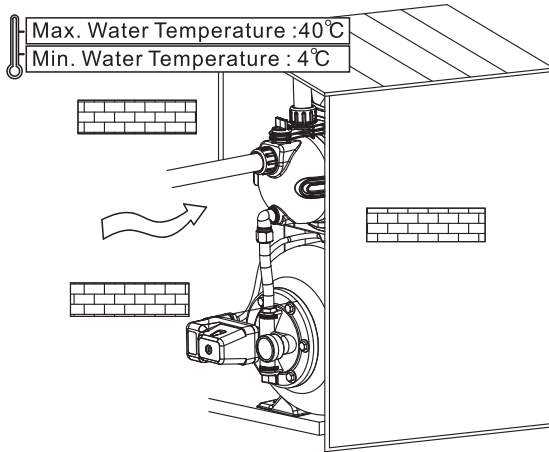

1. For pump installation, the inlet pipe should be as short as possible with the least turnings. The pump should be installed in ventilated and dry environment. It could be installed outside, provided having proper covering to prevent rain and wind.

2. For pipeline use, valves should be installed on inlet and outlet pipelines and the inlet pipeline should be installed with check valve.

**Correct Installation Diagram** A

**A:**

1. Drain Plug	6. Filling plug
2. Tank	7. Tie-in
3. Electric pump	8. Pressure switch
4. Water tap	9. Inlet pipe
5. Outlet pipe	10. Foot valve

**B: Installation precautions for inlet pipelines**

- 1). While installing the electric pump, do not use too soft rubber tube for the inlet pipeline, avoiding to be sucked flat.
- 2). The foot valve should be vertically placed and installed 30cm from water bottom to avoid sucking in sands and stones (B2);
- 3). Joints of the inlet pipelines should be sealed with the least elbows, no water can be sucked.
- 4). Diameter of the inlet pipe should be at least in accordance with that of the water inlet, so as to avoid too much water loss which will influence outlet performance.
- 5). Pay attention to drop of water level while using, the foot valve should not be above the water surface (B1).
- 6). In case the inlet pipe is longer than 10m or its lifting height exceeds 4m, the pipe diameter should exceed diameter of water inlet of the pump.
- 7). Ensure the pumped will not be affected by pipeline pressures while installing the pipelines.
- 8). Filter should be installed in inlet pipelines so as to avoid solid particles to enter into the electric pump.

**C: Installation Precautions of the outlet pipeline**

Pipe diameter of the outlet pipeline should be at least in accordance with that of the water outlet, so as to reduce its voltage drop, high flow rate and noise to the minimum.

**Incorrect Installation Diagram** B

B1

B2