

Termination Kit 4"

This proven, sturdy solution is your choice of cable joining in temporary pump applications or when re-usage of the drop cable is desired. Furthermore, the flexibility and safety it provides for field service conditions makes it the preferred choice over conventional, not breakable splicing kits.

Technical Description:

- Max. current 18 Ampere in air @ max. 50°C ambient temperature
- Max. current 23 Ampere submersed in water @ max. 30°C ambient temperature
- Max. voltage 750 V



Kit- Type	Mod. Number	Description
Standard 304SS	308 090 901	w/o Strain relief Attention: Limited shelf life of Resin and Hardener
Strain Relief 304SS	308 090 902	with. Strain relief Attention: Limited shelf life of Resin and Hardener
Strain Relief 316SS	308 090 953	with. Strain relief Attention: Limited shelf life of Resin and Hardener

Double Plug Lead for Termination Kit

Required for use of lead termination kit. Connected between termination kit and 4" motor.

- max. current 18 Ampere in air @ max. 50°C ambient temperature
- max. current 23 Ampere submersed in water @ max. 30°C ambient temperature
- max. Voltage 750V AC
- PSC / 2-wire / 3-wire and 3 ~ Motors
- Optional strain relief
- Approvals: KTW

4" Standard Motor Design start 07.2016

L (m)	Mat.	Mod. No.	PSC / 3 - wire / 3-Phase
1,5	316SS	309 111 501	3X1,5 & 1G1,5mm ² 1,5 m - w/o. Strain relief
2,5	316SS	309 111 502	



4" High Thrust and Standard Motor Design up to 06.2016

Description	Mat.	2- wire - Mod. Nb.	Description	Mat.	PSC / 3-wire/ 3-Phase
3X1,5mm ²	304SS	310 131 001	3X1,5 & 1G1,5mm ²	304SS	310 111 001
1,5 m - w/o . Strain relief	316SS	310 131 501	1,5 m - w/o. Strain relief	316SS	310 111 501
3X1,5mm ²	304SS	310 131 002	3X1,5 & 1G1,5mm ²	304SS	310 111 002
2,5 m - w/o. Strain relief	316SS	310 131 502	2,5 m - w/o Strain relief	316SS	310 111 502
3X1,5mm ²	304SS	310 132 001	3X1,5 & 1G1,5mm ²	304SS	310 112 001
1,5 m - incl. Strain relief	316SS	-	1,5 m - with. Strain relief	316SS	-
3X1,5mm ²	304SS	310 132 002	3X1,5 & 1G1,5mm ²	304SS	310 112 002
2,5 m - incl. Strain relief	316SS	-	2,5 m - with. Strain relief	316SS	-



4" High Thrust Motor Design 9.3kW

L (m)	Mat.	Mod. No.	3-Phase
1,5	316SS	309 116 501	3X1,5 & 1G1,5mm ² 1,5 m - w/o. Strain relief
2,5	316SS	309 116 502	



Splicing Kit up to 95mm²

Tech. Description	Mod. Nb.	Description	for cross-sections up to [mm ²]	L [mm]	Ø [mm]	H [mm]	Max. cable Ø [mm]
<ul style="list-style-type: none"> • 4 wire • up to 95mm² • up to 1,2kV 	308 090 930	Splicing Kit 10	1.5 - 10	190	36	50	26
	308 090 931	Splicing Kit 25	10 - 25	260	47	63	34
	308 090 932	Splicing Kit 50	25 - 50	360	55	75	43
	308 090 933	Splicing Kit 95	50 - 95	400	70	95	48



Corrosion protection in aggressive water for 4" Standard Motors

Wells with extremely high levels of chlorides and other elements in combination with high temperatures will aggressively attack and corrode nearly any type of metal, including stainless steel. Typical severe applications are geothermal wells and mine wells, and applications with low service times.

Material Specification: GG25

LT Design up to 06.2016	LT starting 07.2016
	
308 250 912	308 250 914

Corrosion protection in aggressive water for 4" High Thrust Motors

Wells with extremely high levels of chlorides and other elements in combination with high temperatures will aggressively attack and corrode nearly any type of metal, including stainless steel. Typical severe applications are geothermal wells and mine wells, and applications with low service times.

These sacrificial anodes, affixed to the motor body, will increase the service life of the motor when used in such environments.

Material Specification: GG25

HT



308 250 913

Motor Filling Liquid

Filling liquid 5 L FES92					
4" Encapsulated	→	FES93	8" Encapsulated Standard	→	FES91
6" Encapsulated Standard & PM	→	FES91	8" Encapsulated HighTemp75	→	FES92
6" Encapsulated HighTemp90	→	FES92	6" / 8" / 10" / 12" Rew Motors 6" / 8" Rew PM Motors	→	FES93

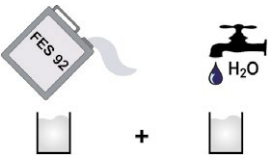

Part number:
308 353 941

FES91	FES92	FES93
		

Motor Filling Kit

This kit contains all necessary tools to check and replenish Franklin Electric submersible motors with FES 91, 92 or 93 filling liquid (fill solution/concentrate must be ordered separately).

Part number: 308 726 103



Couplings

Franklin Electric offers this line of motor-pump couplings for maximum customer convenience in matching the Franklin motor to a variety of pump shafts. Couplings are designed to transmit the pump thrust to the motor in order to provide maximum benefits from the Franklin internal thrust bearing construction.

Hardened stainless steel spacer discs in the 4" and 6" couplings assure positive bearing between motor and pump shafts, and assure full support for downward thrust created by the pump.

8" couplings DO NOT contain hardened spacer discs, since the motor shaft itself is hardened.



4" Motor - Pump couplings

Application: Allow connection of pump to motors shaft.

- Specification:**
- Material: 304 / 316 SS
 - NEMA standard measuring on motor shaft
 - separation washer between motor & pump shafts

Coupling 1	304SS		
	151 551 911		
	Dimension D Max. / Min.	Dimension N Max. / Min.	Dimension H Max. / Min.
	19,075 / 19,063	4,838 / 4,788	20,70 / 20,53

Coupling 2	316SS	
	308 712 904	
	Dimension D Max. / Min.	
	17,50 / 17,48	

6" Motor – Pump Couplings

Application: Allow connection of pump to motors shaft.

- Specification:**
- Material: 304 / 316 SS
 - NEMA standard measuring on motor shaft
 - separation washer between motor & pump shafts

Outline Drawing:

6" Couplings

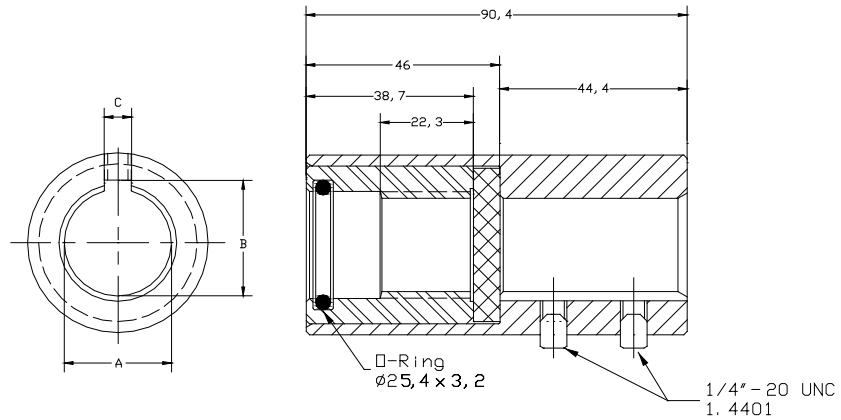

Ordering information

No.	Coupling Material DIN / AISI	Dimension A (mm) Max. / Min.	Dimension B (mm) Max. / Min.	Dimension C (mm) Max. / Min.
151 935 902	1.4005 (304)	19,075 / 19,063	20,70 / 20,52	4,84 / 4,79
151 935 922	1.4401 (316SS)			
151 935 910	1.4005 (304)	20,025 / 20, 013	22,76 / 22,60	6,05 / 6,00
151 935 927	1.4401 (316SS)			
151 935 908	1.4005 (304)	22,025 / 22,013	25,53 / 25,32	8,03 / 7,98
151 935 928	1.4401 (316SS)			
151 935 901	1.4005 (304)	22,250 / 22,238	24,54 / 24,36	6,43 / 6,38
151 935 921	1.4401 (316SS)			
151 935 906	1.4005 (304)	25,025 / 25, 013	28,70 / 28,30	8,03 / 7,98
151 935 926	1.4401 (316SS)			
151 935 909	1.4005 (304)	25,425 / 25,413	27,74 / 27,56	6,43 / 6,38
151 935 929	1.4401 (316SS)			

8" Motor-Pump Couplings

**Outline
Drawing:**

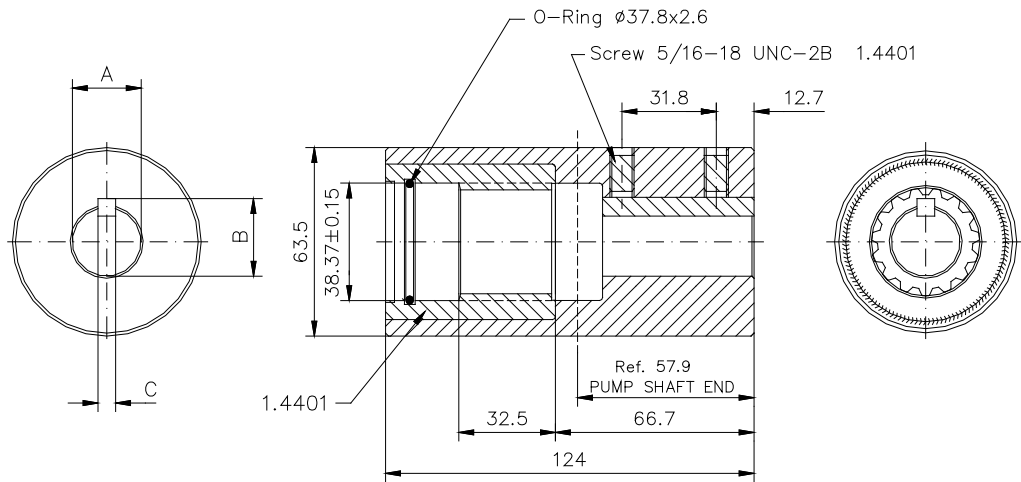

**Ordering
information**

Part No.	Coupling Material DIN / AISI	Dimension A (mm) Max. / Min.	Dimension B (mm) Max. / Min.	Dimension C (mm) Max. / Min.
156 563 901	1.4005 (304)	25,425 / 25,413	28,27 / 28,17	6,38 / 6,32
156 563 921	1,4404 (316SS)			
156 563 902	1.4005 (304)	30,188 / 30,175	33,73 / 33,63	7,96 / 7,91
156 563 922	1,4404 (316SS)			
156 563 903	1.4005 (304)	31,775 / 31,763	35,36 / 35,26	7,96 / 7,91
156 563 923	1,4404 (316SS)	38,125 / 38,113		
156 563 904	1.4005 (304)	38,125 / 38,113	42,37 / 42,27	9,55 / 9,50
156 563 924	1,4404 (316SS)	38,125 / 38,113		
156 563 905	1.4005 (304)	19,085 / 19,063	20,70 / 20,52	4,84 / 4,79
156 563 906	1.4005 (304)	30,188 / 30,175	33,02 / 32,92	6,38 / 6,32
156 563 926	1,4404 (316SS)	30,188 / 30,175	33,02 / 32,92	6,38 / 6,32
156 563 907	1.4005 (304)	22,250 / 22,238	24,54 / 24,36	6,43 / 6,38
156 563 908	1.4005 (304)	22,024 / 22,011	25,53 / 25,32	8,03 / 7,98
156 563 931	1,4404 (316SS)			
156 563 929	1,4404 (316SS)	42,888 / 42,850	47,12 / 47,04	9,55 / 9,50
156 563 909	1.4005 (304)	25,024 / 25,011	28,70 / 28,30	8,03 / 7,98
156 563 932	1,4404 (316SS)			



PT100 for 6" and 8" Encapsulated Motors

The PT100 is a precision platinum wire resistor that is specified occasionally as a temperature input for process control equipment. A jacketed control lead must be run from the PT100 lead to the above-ground equipment. The above-ground equipment is not available from Franklin Electric and is typically part of a custom panel or data acquisition system.

PT100 sensor retrofit kits from Franklin Electric come with complete instructions and allow for easy field installation.

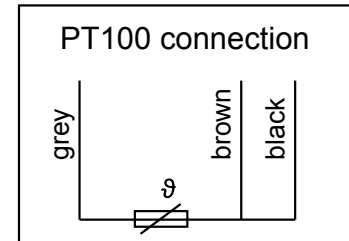
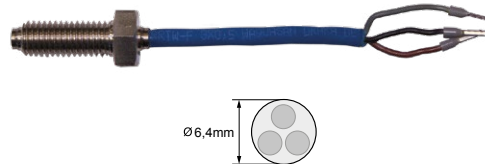
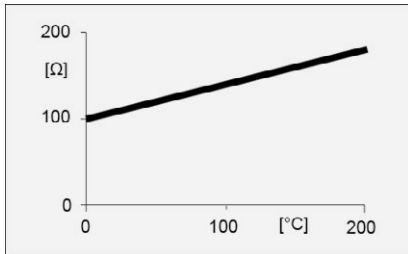

To install the PT100 sensor bolt, remove the top end bell bolt that is opposite of the lead and replace it with the PT100 screw. Tighten the sensor bolt to the torque values shown below.

6" PT100 - 4kW- 45kW	54- 61 Nm
8" PT100 - 30kW- 45kW	54- 61 Nm
55kW- 150kW	115- 122 Nm

Franklin Electric does not offer the required sensing device, it is available from speciality dealers.

Conditions	Temp. of the water without motor operation	Max. Trip temp. / Resistance Setting (for standard Lead length)
Motor operating at nameplate output with 0.16 m/sec flow past the motor	10°C	40°C / 115,5 Ω
	15°C	44°C / 117,0 Ω
	20°C	48°C / 118,6 Ω
	25°C	51°C / 119,7 Ω
	30°C	55°C / 121,3 Ω
Motor that has been Derated with 1 m/sec flow past the motor	35°C	59°C / 122,8 Ω
	40°C	63°C / 124,3 Ω
	45°C	66°C / 125,5 Ω
	50°C	70°C / 127,0 Ω
	55°C	74°C / 128,6 Ω
	60°C	78°C / 130,1 Ω

6" PT100 CT

Kit Number	Motor Type	Wire Insul.	max. Medium Temp.	Lead (mm ²)	Lead length (m)
305 327 903	6" all Ratings ½ - 13 UNC Europe Motors starting 07.2002 US Motors starting 11.2001 on	Rubber	60°C	3X0,5	10

8" PT100 CT

Kit Number	Motor Type	Wire Insul.	max. Medium Temp.	Lead (mm ²)	Lead length (m)
305 326 902	30 - 45kW (Type 2.1)	Rubber	60°C	3X0,5	10
305 326 901	55 - 150kW (Type 1)	Rubber	60°C	3X0,5	10

6" / 8" Encapsulated PT100 HighTemp

Its ohmic resistance is proportional to the sensed temperature. The FE field replaceable PT100 is potted into a screw holding the upper end bell. Because of his remote position relative to the windings, the sensing relay should be adjusted according to the below table.

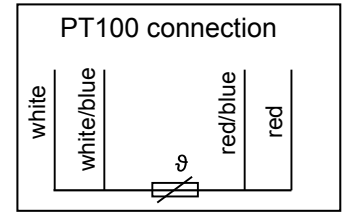
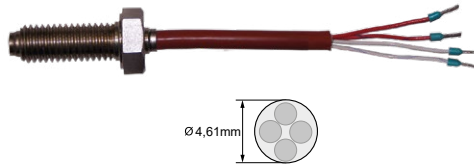
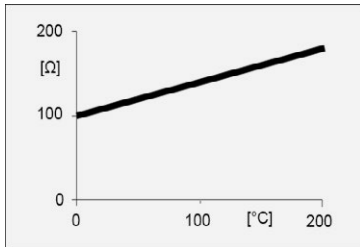

To install the PT100 sensor bolt, remove the top end bell bolt that is opposite of the lead and replace it with the PT100 screw. Tighten the sensor bolt to the torque values shown below.

6" PT100 - 4kW- 30kW 54- 61 Nm
 8" PT100 - 30kW- 110kW 115 - 122 Nm

Franklin Electric does not offer the required sensing device, it is available from speciality dealers.

Conditions	Temp. of the water without motor operation	Max. Trip temp. / Resistance Setting
Motor operating at nameplate output with 0.16 m/sec flow past the motor	50°C	60°C
	60°C	70°C
	70°C	80°C
	75°C	85°C
	80°C	90°C
	90°C	100°C

6" PT100 HighTemp90

Kit Number	Motor Type	Wire Insul.	max. Medium Temp.	Lead (mm ²)	Lead length (m)
156 098 111K	4 - 30kW	Silicon	90°C	4X0,35	10
156 098 112K		Silicon	90°C	4X0,35	130

8" PT100 HighTemp75

Kit Number	Motor Type	Wire Insul.	max. Medium Temp.	Lead (mm ²)	Lead length (m)
156 098 116K	30 - 110kW (Type 1)	Silicon	90°C	4X0,35	10
156 098 117K		Silicon	90°C	4X0,35	130

PT100 Rewindable Motors

- Fitted into the upper end bell flange , all end bells 6" ,8" , 10" and 12" Rewindable are prepare for installation PT100
- Measures the temperature of the filling liquid
- Conductor with a resistance proportional to the temperature
- Allows monitoring the temperature continuously

The above-ground equipment is not available from Franklin Electric and is typically part of a custom panel or data acquisition system. PT100 sensor retrofit kits from Franklin Electric come with complete instructions and allow for easy field installation.

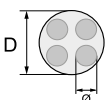

	Ø [mm ²]	D [mm]	Lead Lengths [m]	Mod.- No.:	6" Rew Redesign starting 08.2012		6" (Cast Iron/304SS) / 8" / 10" / 12"	
					304/316	904L	304/316	904L
PT 100	4X0,5	8	10		308 016 501	308 016 522	308 016 401	308 016 422
PT 100	4X0,5	8	20		308 016 502	-	308 016 402	-
PT 100	4X0,5	8	30		308 016 503	-	308 016 403	-
PT 100	4X0,5	8	50		308 016 505	308 016 526	308 016 405	308 016 426

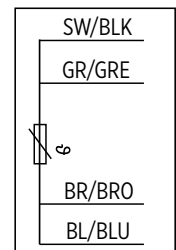

Trip Points:
 PVC = 55°C
 PE2/PA = 75°C

6" Permanent Star Plug

For some applications it may be necessary to permanently run a star-delta submersible motor in star connection. This may be achieved by using the PERMANENT-STAR-PLUG. This connector short - circuits all three pins in one of the two motor sockets and is designed to replace one lead.

Part- Nb.: 304- 308 065 901

Part- Nb.: 316SS - 308 065 951



Surge Arrestor

These surge arrestors or their equivalents are highly recommended for protecting submersible motors from a variety of commonly occurring high voltage spikes which can damage the motor insulation system and cause motor winding failure. These arrestors will not, as is true of any surge protection equipment, protect the motor from a direct lightning strike.

Part-Nb.: 155 440 902

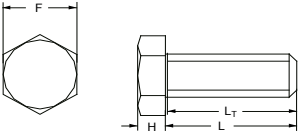
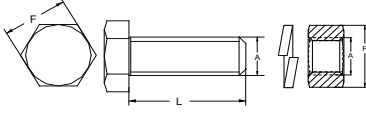
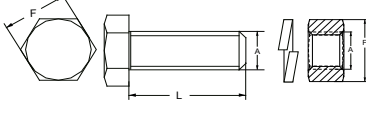

Pump connection screw Kit's

	Motor Type	Material	L / L _T [mm]	H [mm]	F [mm]	Mod.- Nr.:
	6" CT	316SS	38,1	8	19	308 659 318
	Motor Type	Material	L [mm]	A [mm]	F [mm]	Mod.- Nr.:
	8" CT / 8" REW	316SS	70	M16	24	308 659 327
	Motor Type	Material	L [mm]	A [mm]	F [mm]	Mod.- Nr.:
	10" / 12" REW	316SS	80	M20	30	308 659 319

PTC Lead (only as spare parts)

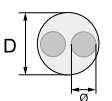
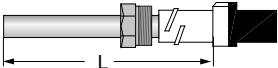
$\varnothing = 2 \times 0,75 \text{ mm}^2$	D = 7,0 mm	L (m)	Mod.-No.
		4	310 364 004
		10	310 364 010
		20	310 364 020
		30	310 364 030

Flow Paddle Switch

The flow switch utilizes the force of liquid flow to propel its paddle and to detect the incoming flow or movement of the existing liquid in the pipe. For Flow rates above 4m³/h; Connection: G1 "



Mod.Nb.: 226 019 101

Inline Flow Switch

The Inline Flow Switch operates magnetically. The piston within the switch body should be a free fit and spring back to its off position as soon as flow stops. For flow rates up to 4 m³/h; Connection: G1"



Mod.Nb.: 226 014 101

Level Switch

A float switch is a device used to detect the level of liquid within a tank. A required Part of the 6" High Efficiency Solar System.
Lead lenght: 10m

Mod.Nb.: 308 170 209



DC Disconnect

To disconnect the drive even under load safely from the solar generator, Franklin Electric offers suitable DC disconnect switches for all different power ratings.

0 - 13A/800V DC - 308 170 313

12 - 22A/800V DC - 308 170 325

25A/800V DC - 308 170 325



Pressure Switch SubDrive Constant- pressure Controller

The pressure switch signals continuously prevailing in the water supply system pressure to the SubDrive controller. The factory setting of the desired pressure is 3,4bar; can be changed.

Mod.Nr.: 223 995 901



Pressure Switch SubDrive Connect

The pressure switch signals continuously prevailing in the water supply system pressure to the SubDrive controller.

Mod.Nr.: 226 905 906





Franklin Electric

Franklin Electric Europa GmbH
Rudolf Diesel Strasse 20
54516 Wittlich / Germany

Single member - Company subject to the control
and coordination of Franklin Electric Co., Inc.

NOTE: Franklin Electric Europa GmbH reserves the right to amend specification without prior notice.

