

Encapsulated Submersible Motors, 6" and 8"

GB

Assembly and operating instructions



Franklin Electric

Franklin Electric Europa GmbH
Rudolf-Diesel-Straße 20
D-54616 Wittlich, Germany
Tel.: +49 (0) 65 71 / 105 - 0
Fax: +49 (0) 65 71 / 105 - 520

E-Mail: service-de@franklinwater.eu
Internet: www.franklinwater.eu

Doc.-Nb.: 308 018 418
Version: Rev.18; July 2020

1	With this document	2
1.1	Warning notices and warning symbols	2
1.2	Instructions and highlights	2
2	Safety	3
2.1	Intended use.....	3
2.2	Target group.....	3
2.3	General safety instructions	3
3	Storage, transport, disposal	4
4	Technical specifications	4/5
5	Putting the motor into use	6
5.1	Checking the motor prior to installing it.....	6/7
5.2	Motor and pump assembly	7
5.3	Motor cable.....	7/8
5.4	Measuring the insulation resistance	8/9
5.5	Making the electrical motor connection	9/10
6	Motor operation	11
6.1	Making sure that the motor is cooled sufficiently	11/11
6.2	Providing a check valve and a level sensor	11
6.3	Switching on the motor	11
6.4	Operating a motor with a frequency converter.....	11
6.5	Operating a motor with a soft starter	12
7	Maintenance and service	12
8	Troubleshooting	12
9	Service	12
10	Appendix	12

© Copyright by Franklin Electric Europa GmbH 2005

All rights in these instructions are reserved – specifically the copying, distribution and translation rights. No part of these instructions shall be reproduced, or processed, copied or distributed using electronic systems or otherwise without the prior permission in writing of Franklin Electric Europa GmbH.

Changes due to technical developments reserved.

1 With this document

These assembly and operating instructions form an integral part of the submersible motor and describe its safe, intended use in all operating phases.

Storage and handing over

- ⇒ Keep the assembly and operating instructions in the immediate vicinity of the motor.
- ⇒ Hand the assembly and operating instructions over to every subsequent user of the motor.

Application

These assembly and operating instructions only apply to the motors described here.

1.1 Warning notices and warning symbols

Warning notices point out special dangers and indicate the measures that can be taken to avoid the danger. Warning notices come in three levels:

Warning word	Meaning
DANGER	Immediate danger to life and health
WARNING	Possible danger to life and health
CAUTION	Possible danger of slight injury or material damage

Warning notices are built up as follows:



Warning word

Type and source of danger as well as the possible consequences of measures not being observed!

- ⊙ *Forbidden actions.*
 - ⇒ *Measures to avoid the danger.*
-

1.2 Instructions and highlights

In these assembly and operating instructions, we use the following symbols and, for improved legibility and uniform identification, highlights:

- Insulation measuring unit (this indicates a listing)
- ☑ Instructions ... observed (this indicates a condition)
- ⇒ Switch off the motor. (this indicates an instruction to take action)
- Motor has stopped. (this indicates the result of the action)
- Immediately switch off** the motor... (you can see a highlight in bold here)



Note

Specifically, important information is given here. You should observe this information to ensure correct and safe operation of the motor.

2 Safety

This section describes the safety rules which you have to observe for the safe use of submersible motors. Possible sources of danger and the relevant safety measures are listed here.

2.1 Intended use

Franklin Electric submersible motors are only intended for integration with a machine in order to drive the relevant machine under water. They must only be put into use if the machine fulfils the provisions of the applicable directives and statutory provisions.

Installation location: Vertical (Mandatory mounting position: vertical, shaft up. Only one diameter step allowed, i.e. 6" motor on 8" pump). Horizontal (only allowed if the pump size is identical to the motor size, e.g. 6" motor with 6" pump). The pump has to sufficient "Down Thrust" transmit to the motor.

The submersible motors must only be used in clean, highly fluid media, such as drinking or process water.

The following media are not allowed: air, highly flammable, explosive media and wastewater.

Loss of guarantee and exclusion of liability

Franklin Electric shall not be liable for the damage resulting from any further, non-intended use. The risk of such use rests solely with the user.

2.2 Target group

The electrical system must only be installed by professional staff (qualified electrical engineers or electrical machine technicians).

2.3 General safety instructions

The following safety measures must be observed prior to putting the motor into use:

- Do not carry out any other work on the motor than described in these instructions.
- Only use the motor under water (the motor and the short motor cable must be fully submersed).
- Do not implement any changes or conversions to the motor or its electrical connections.
- Never open the motor.
- Never use the motor in combination with damaged pump units or parts.
- Only work on the motor when it is switched off. No work or checks require the motor to be running.
- Switch off the power supply to the motor before carrying out any work on it.
- Make sure that nobody can switch on the voltage unexpectedly while work is being carried out on the motor.
- Never work on electrical systems during a thunderstorm.
- Make sure immediately after ending the work that all protective and safety devices have been fitted again and are operational.
- Before switching on the motor, make sure that all electrical connections and safety devices have been checked and that all fuses and safeties have been set correctly.
- Make sure that no danger zones are freely accessible (e.g. rotating parts, suction locations, pressure output locations, electrical connections).
- Observe the pump manufacturer's commissioning instructions.
- If motors or pump units have been used in contaminated media they must be marked as such before handing them over to a third party (e.g. when submitting them for repair). Pay attention to possible residues in "Dead spaces" (diaphragm cover).
- Repairs must only be carried out by authorized professional workshops. Use only original Franklin Electric spare parts.
- Observe warning notices attached to the motor

3 Storage, transport, disposal

- Storage**
- ⇒ Store the motor in its original packaging until the time of installing it.
 - ⇒ If the motor is stored standing up, make sure that it cannot topple over (shaft always pointing up!).
 - ⇒ Do not store the motor in direct sunlight or within the reach of other heat sources.
 - ⇒ Observe the storage temperature (–15 - +60 °C, see Technical specifications).

Transport



Falling loads may cause lethal injuries or may crush parts of the body!

- ⊙ Nobody is allowed to be located under suspended loads.
 - ⇒ Only use approved hoisting gear.
 - ⇒ Select the hoisting gear on the basis of the total weight to be transported.
-

Unpacking

- ⇒ After unpacking the motor check it for possible damage, e.g. damage to the diaphragm cover, housing, endbell, connection and motor cable.
- ⇒ Immediately inform the supplier of any damage found.



Danger to life due to electrocution if the motor cable is damaged!

- ⊙ Do **not** install the motor and do **not** put it into operation.
-

Disposal

In order to avoid environmental damage:

- Avoid contamination by lubricants, detergents etc.
- Dispose of the motor and the packaging material in a proper, environmentally sound manner.
- Observe local regulations.

4 Technical specifications

Description	Value
Performance/model number	6": 4 - 45 kW (HighTemp90 up to 30 kW) models 236 ... (276 ...) 8": 30 - 150 kW (HighTemp75 up to 110 kW) models 239 ... (279 ...)
Voltage range	220 V ... 690 V, 3~ 50/60/100/120 Hz
Frequency tolerance	± 2%
Voltage tolerance (on the motor terminals)	50 Hz: –10 / +6 % of U _N , i.e. at a nominal voltage of 380-415 V: 380V –10 % = 342V / 415V + 6 % = 440 V 60/100/120 Hz: +/- 10% of U _N
Speed	approx. 2900 rpm at 50 Hz & 3450 rpm at 60 Hz, 100 Hz approx.. 3000 rpm
Start alternatives	Direct starting, wye-delta-starting
Switching frequency	6" - Max. 20 switching actions per hour with a minimum off time of 3 min. 8" - Max. 10 switching actions per hour with a minimum off time of 3 min.
Protection	IP 68 according to IEC 60529
Insulation class	F (155°C)

5 Putting the motor into use

5.1 Checking the motor prior to installing it

If a leak is visible or if the motor is more than one year old (e.g. in the event of re-use or after long storage):

⇒ Check the fluid level in the motor prior to installing it.

Tools You need the following tools for assembly and inspection work:

- Insulation measuring unit: 500 VDC testing
 - Filling Kit 308 726 103
- ⇒ Determine the age of the motor by checking the type plate (see Figure 5-1).

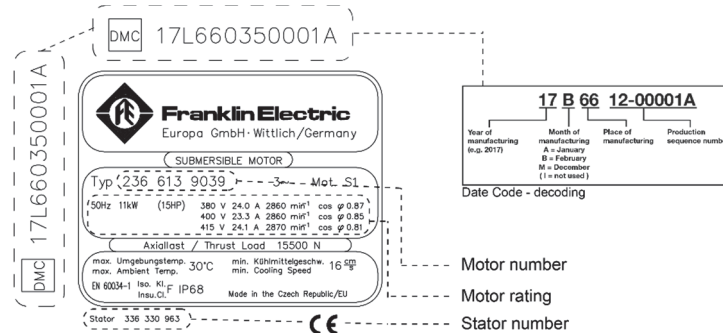

Figure 5-1: Type plate with date of manufacture

5.1.1 Checking the motor fluid



Motor damage due to being insufficiently filled!

- ⇒ Fill the motor with sufficient motor fluid
- ⇒ Wear safety goggles and gloves when filling and draining the motor.

⇒ Top up using original motor fluid from Franklin Electric (5 litres concentrate Id. no. 308 353 941)
Never use distilled water!

- Filling volumes**
- 6": max. 1.5 liter
 - 8": max. 3.5 liter

Venting the motor

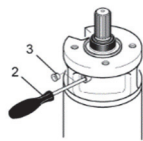

Figure 5-2: Venting the motor

- ⇒ Place the motor horizontally so that the filling valve is located at the highest position.
- ⇒ Remove the plug (3) from the filling valve.

Carefully push the test pin (2) into the filling valve until air and some fluid escape from it.

Checking the motor

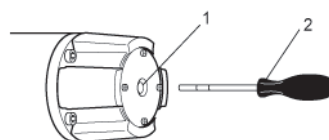

Figure 5-3: Checking the motor fluid

- ⇒ Feed the test pin (2) through the opening (1) in the diaphragm housing until you can feel resistance.
- ⇒ Measure the actual diaphragm distance to the side of the opening in the diaphragm cover.
If the measured result is not identical to the target value:
59 mm ± 2 mm (6"- motor-WW 4-30kW)
25 mm ± 2 mm (6"- motor-304SS/316SS / 4-30kW)
47 mm ± 2 mm (6"- motor-304SS/316SS - 37/45kW)
47 mm ± 2 mm (6"- HighTemp90, 304SS/316SS)
44 mm ± 2 mm (6"- 45kN Version)
37 mm ± 2 mm (8"- motors all)

Topping up the motor

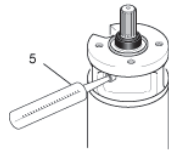

Figure 5-4: Topping up the motor fluid

- ⇒ Top up or drain motor fluid.
- ⇒ Apply the filling syringe (5) to the filling valve.
- ⇒ Top up the motor filling fluid until the value of the diaphragm position is lower than the target value.

- Adjusting the motor**
- ⇒ Adjust the diaphragm position by draining (see Venting) or topping up motor fluid until the target value is reached.
 - ⇒ Fit the plug (3) again.

5.2 Motor and pump assembly



Note

This assembly and operating instructions only describe action steps related to the motor. You should also observe the pump unit manufacturer's instructions in all events.

- Preparation**
- Short motor cable fitted (see 5.3.1)
 - Shaft protector removed
 - Motor shaft rotated manually before assembly – runs freely after overcoming static friction
 - Surfaces of parts to be connected are free from dust and dirt
 - Coupling attached to the pump shaft, slides on the motor shaft

Assembly

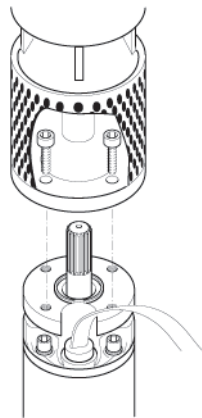

Figure 5-5: Pump assembly

- ⇒ Apply water-resistant, FDA approved, approved-free grease (e.g. Mobil FM 102, Texaco Cygnus) to the inner part of the coupling to the pump unit.
- ⇒ Make sure that the splined section is encased by an O-ring when the motor and the pump unit are assembled together.
- ⇒ Align the pump unit and motor shaft to each other, connect the pump unit and the motor.
- ⇒ Screw the motor to the pump unit, tighten the fixing screws crosswise as instructed.
 - 6": ½"-20 UNF-2B
 - 8": Bore Ø 17.5 mm
- ⇒ Protect the coupling location against contact.

5.3 Motor cable



CAUTION

Motor damage due to damaged motor cable!

- ⇒ Make sure that the motor cable is not in contact with any sharp edges.
- ⇒ Protect the cable against damage using the cable guard.

5.3.1 Connecting the short motor cable



Note

⇒ Always a **new** cable must be used

Tools and Torques

You need to use the following tools and torques for assembly and inspection work:

- 6" Motors WW (all Ratings) 60 N/m ±6 N/m; Wrench 1 3/16" (30,2 mm)
- 6" Motors 304SS/316SS (all Ratings) 60 N/m ±6 N/m; Wrench 1 3/16" (30,2 mm)
- 8" Motors (30 – 93kW) 74 N/m ±7 N/m; Wrench 1 3/16" (30,2 mm) oder 1 5/8" (42 mm)
- 8" Motors (110 – 150kW) 9,0 N/m ±1 N/m, Allen Key 3/16" (4,7 mm)

Preparation

- Remove the sealing plug (1)
- Clean and dry the surfaces of the plug (2) and the socket (3)

Assembly

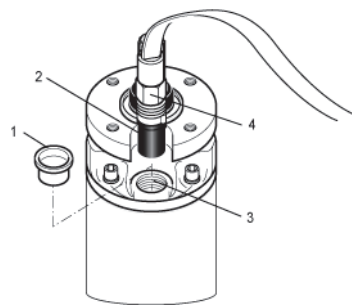

- ⇒ Pull back the jam nut (4) until the plug (2) is free
- ⇒ Apply FDA approved grease or Vaseline to the rubber casing surfaces
- ⇒ Apply acid-free grease to the thread of the union nut
- ⇒ Insert the plug (4) in the socket (3)

Figure 5-5: Connection of the short motor cable

5.3.2 Extending the motor cable

- The unit manufacturer's instructions regarding the cable connection have been observed
- Only extension cable and insulating material used which are suitable for the specific use (specifically drinking water) and which are approved for the temperatures occurring in the relevant medium
- Cable cross-sections: The tables in the appendix only serve as recommended suggestions. The fitter is responsible for the correct selection and dimensioning of the cable
- ⇒ Lay the cable along the pump.
- ⇒ Connect the ground conductor correctly (motors or integrated ground conductors are prepared for external grounding).
- ⇒ Protect the cable connection location against water penetration (shrink hoses, compounds or ready cable sets).
- ⇒ Make sure that the short motor cable is always fully surrounded by transport medium for proper cooling during operation.

5.4 Measuring the insulation resistance

This measurement is to be carried out using an insulation measuring unit (500 VDC) before and while submersing the fully assembled unit at the place of use.

- ⇒ Before submersing the unit, connect a measuring cable to the ground conductor.
- ⇒ Make sure that the contact points are clean.
- ⇒ Connect the other measuring cable to every core of the connected motor cable in succession. The insulation resistance is shown on the insulation measuring unit.

For your information Minimum insulation resistance (500 VDC; 1 min.; 20°C) **with extension cable:**

- for a new motor > 4 MΩ
- for a used motor > 1 MΩ

Minimum insulation resistance (500 VDC; 1 min.; 20°C) **without extension cable:**

- for a new motor > 400 MΩ
- for a used motor > 20 MΩ

5.5 Making the electrical motor connection



Danger to life due to electrocution!

⇒ Prior to making the electrical motor connection make sure that there is no more voltage on the entire plant and that nobody can accidentally switch on the voltage again while the work is being carried out.

Observe the instructions on the motor type plate and dimension the electrical system accordingly. The connection examples in this chapter concern the actual motor and do not serve as recommendation for the upstream control elements.

- All action steps of the previous chapter have been carried out properly
- Additional safety instructions for submersible synchronous motors

Energy supply by generator



Note

We urgently recommend that you discuss the plant dimensions with the generator manufacturer.

The voltage tolerance -10 % to +6 % -50Hz and +/-10% - 60Hz motors (on the motor terminals) and the deviation of a motor current from the mean value of all three currents must not be more than 5 %.

- Generator selected on the basis of the motor start behaviour, i.e. starting current with a mean $\cos \phi$ of 0.5
 - Sufficient continuous generator power available
 - Voltage at start at least 55 % of the nominal voltage
- ⇒ You must follow the following switch-on sequences unconditionally:
 first switch on the generator and then the motor.
 first switch off the motor and then the generator.

Fusing and motor protection

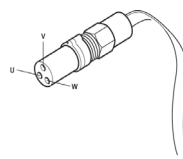
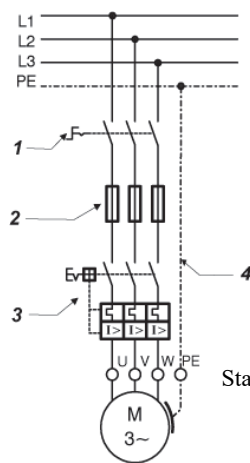

- ⇒ Provide an external mains switch (1) enabling the voltage to be removed from the system.
- ⇒ Provide fuses (2) for every single phase on site.
- ⇒ Provide a motor starting and protection switch (3) (see connection alternatives)
- ⇒ Provide an emergency stop system, if required for your specific application.
- ⇒ Ground the motor (4) (exterior grounding possible with all motors)

Standard:

U = black
V = grey (blue)
W = brown

6" PM

U= grey
V= brown
W= black

6" HiTemp90

U= black
V= white
W= red

Figure 5-10: Fusing and motor protection

Surge voltage protection

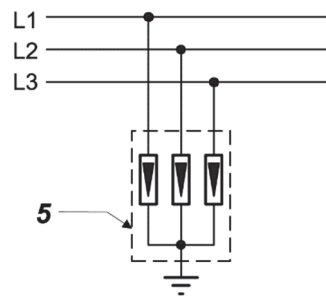

⇒ Integrate an overload protector in accordance with IEC 60099 in the power supply (lightning safety (5)).

Figure 5-12: Surge voltage protection

Connection alternatives

The motors can be used for clockwise and anti-clockwise rotation. The connection example shows the usual circuit with a right-hand field and an anti-clockwise direction of rotation:

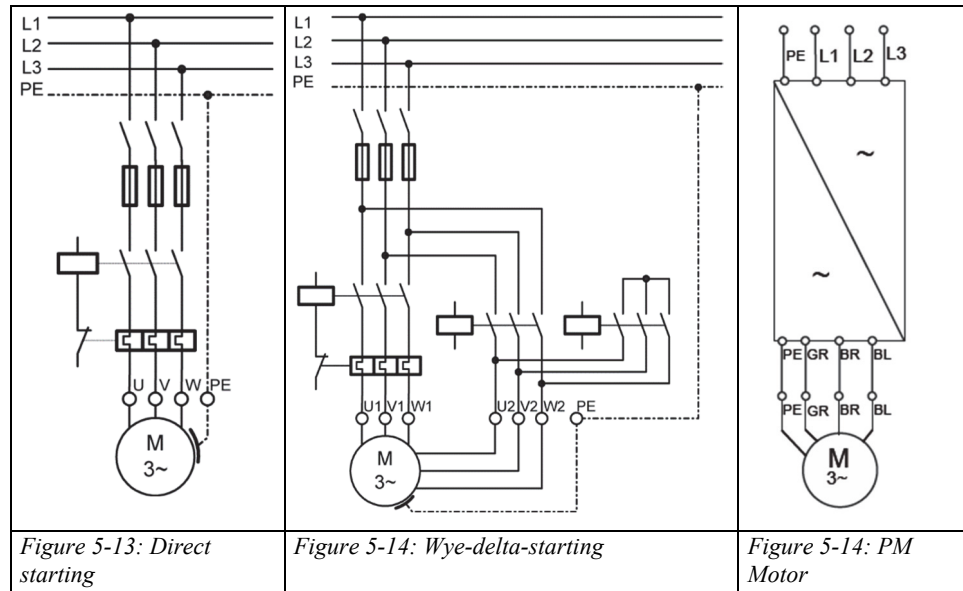

Motor safety switch

A motor safety switch (overload relay) is absolutely necessary!

Only use thermal trips of tripping categories 10A or 10, with

- ⇒ tripping time < 10 s at 500 % I_N (nominal current),
- ⇒ phase sensitivity,
- ⇒ temperature compensation from 20 to 40 °C.
- ⇒ Set the motor protection unit to the value of the operating current measured without exceeding the rated motor current I_N (as indicated on the type plate).

6 Motor operation

6.1 Making sure that the motor is cooled sufficiently



Caution

Damage to the motor and the motor cable due to overheating

- ⇒ Make sure that the coolant flow speed along the motor is sufficient.
- ⇒ Make sure that the short motor cable is always fully surrounded by transport medium for proper cooling.

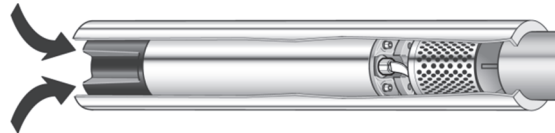

Figure 6-1: Cooling tube

If the required minimum coolant flow speed cannot be reached (e.g. if the inlet opening of the well is located above the motor or if using large-diameter wells):

- ⇒ Fit a cooling tube (see figure 6-1).
- ⇒ Make sure that the cooling tube encases the entire motor and the pump water inlet opening.
The motor is force-cooled.

6.2 Providing a check valve and a level sensor

- ⇒ Provide one spring-loaded check valve in the production tube in case no such check valve has been fitted in the pump.
- ⇒ Ensure that the first check valve is no further than 7 m (metres) away from the pump.
- ⇒ Install a level sensor for wells with a highly varying water inflow.

6.3 Switching on the motor

- ☑ All action steps of the previous chapter have been carried out properly
- ⇒ Switch on the motor using the mains switch in the control cabinet.
- ⇒ Measure the following values after switching on:
 - Motor operating current in every phase
 - Mains voltage when motor is running
 - Level of the medium to be transported
- ⇒ **Immediately switch off the motor if:**
 - the nominal current as specified on the type plate is exceeded,
 - voltage tolerances of more than -10 % / +6 % to 50Hz and +/- 10% to 60Hz, relative to the nominal voltage are measured on the motor,
 - there is a risk of the motor running dry,
 - a motor current deviates from the mean value of all three currents by more than 5 %.

6.4 Operating a motor with a frequency converter



Note

When operating a motor with a frequency converter, the relevant operating manual must be observed!

- ⇒ VFD operation is only permitted up to a supply voltage of 460 V. For higher voltages, please contact Franklin Electric Europa GmbH.
- ⇒ Make sure that the motor current in all operating levels of the regulating range does not exceed the nominal motor current indicated on the type plate.

- ⇒ Adjust the frequency converter so that the limit values for the nominal motor frequency of min. 30 Hz and max. the value of the nominal motor frequency are observed.
- ⇒ Limit any voltage peaks on the motor when using a frequency converter to the following values: max. voltage rises 500 V/μs, max. voltage peak 1000V.
- ⇒ Make sure that the running up time from 0 to 1800 rpm and the deceleration time from 1800 to 0 rpm is maximum one second.
- ⇒ Dimension the cable such that power loss due to additional filters is taken into consideration.
- ⇒ Make sure that the required coolant flow speed along the motor is also observed with frequency converter operation.

6.5 Operating a motor with a soft starter



Note

When operating a motor with a soft starter, the relevant operating manual must be observed!

- ⇒ Set the starting voltage of the soft starter to 55 % of the nominal voltage and set the running up and delay times to max. three seconds.
- ⇒ Bridge the soft starter after running up, using a contactor.

7 Maintenance and service

The motor is maintenance-free; no maintenance or service activities are necessary.

8 Troubleshooting

Fault	Remedy
Unusual noises, problems with the true running of the pump or the pump switching on and off too frequently.	⇒ Try to find the cause of the fault on the pump unit.
The pump repeatedly switches off	<ul style="list-style-type: none"> ⇒ Have the insulation resistance checked by a professional (see chapter 5.4). ⇒ If no cause can be found in the motor or the motor cable: Have the electrical system checked.

9 Service

- Repairs must only be carried out by authorised professional workshops (only use original Franklin Electric spare parts).
- Please note the additional safety instructions for submersible synchronous motors
- If you have any questions or problems, please contact your dealer or contact Franklin Electric via web: franklinwater.eu or mail to service-de@franklinwater.eu.

10 Appendix

Page	Explanation
Page A	Outline drawings 6" / 8" Standard Motors
Page B	Outline drawings HiTemp 75/90 Motors
Page C	Motor Test Report (MTR)
Page D	Cable cross-sections DOL and YD

6" Encapsulated

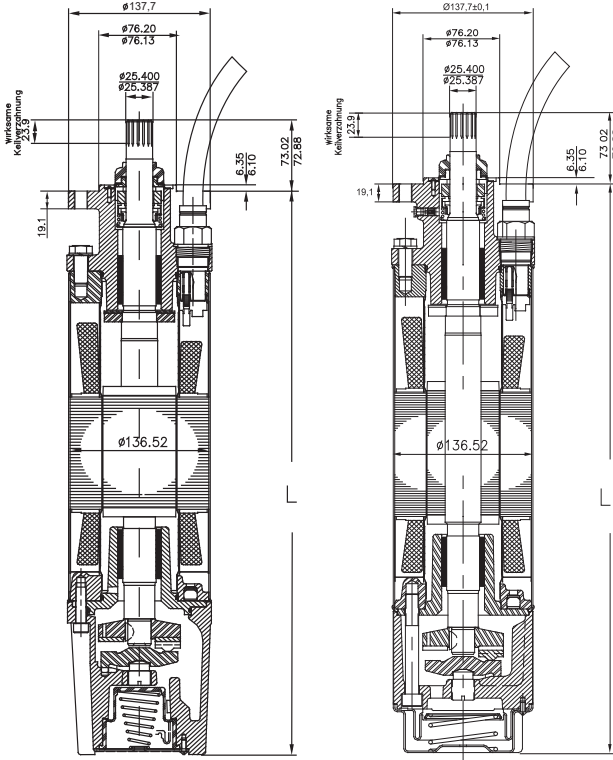
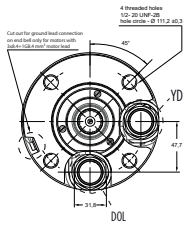

WW (Water Well)

304SS / 316SS

6" Encapsulated PM

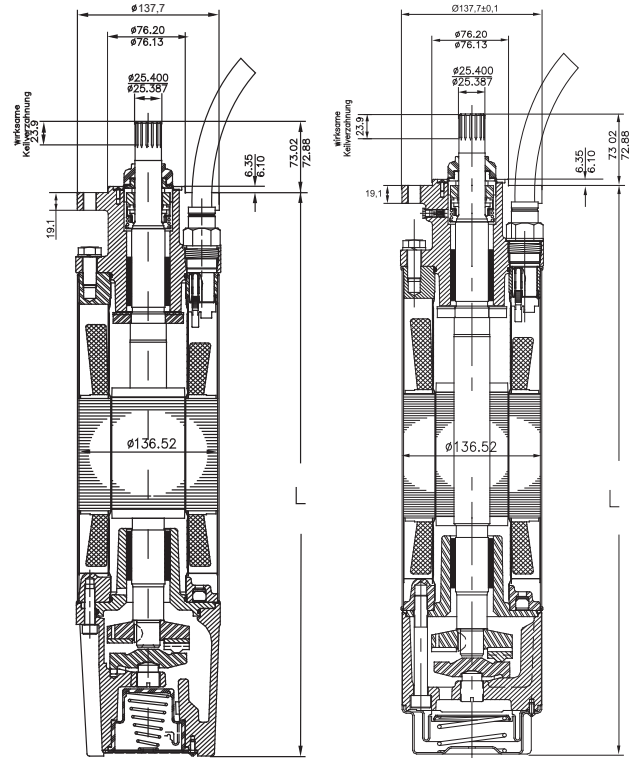
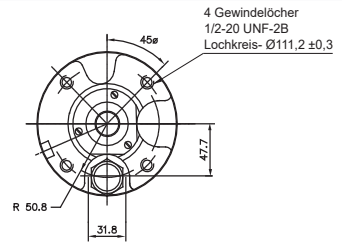

WW (Water Well)

304SS / 316SS

P _N [kW]	WW L [mm]	304SS* L [mm]	316SS** L [mm]	Motor Package Size [mm]	Shipping Weight [kg]***	
					DOL	YΔ
4	581,2	570,7	570,7	155 x 212 x 800	41,3	40,3
5,5	614,4	604,0	604,0		44,9	43,9
7,5	646,2	635,8	635,8		49,0	48,0
9,3	678,7	668,3	668,3	155 x 212 x 1070	51,3	50,3
11	711,2	700,8	700,8		54,7	53,7
15	776,2	765,8	765,8		60,5	59,5
18,5	841,5	831,1	831,1		67,1	66,1
22	906,5	896,1	896,1		73,1	72,1
30	1036,6	1026,2	1026,2	155 x 212 x 1200	87,7	87,7
37	-	1476,7	1476,7	223 x 267	136	
45	-	1629,2	1629,2	x 1823	156	

P _N [kW]	WW L [mm]	304/316 L [mm]	Motor Package Size [mm]	Shipping Weight [kg]
4 - 11	634,5	625,2	155 x 212 x 800	45
13 - 22	793,5	784,2	155 x 212 x 1070	61
26 - 45	1020,5	1011,2		84

* HighThrust Version + ~60mm

** HighThrust Version + ~70mm

*** HighThrust Version + ~4Kg



**6" Encapsulated
HighTemp 90°C**

8" Encapsulated

**8" Encapsulated
HighTemp 75°C**

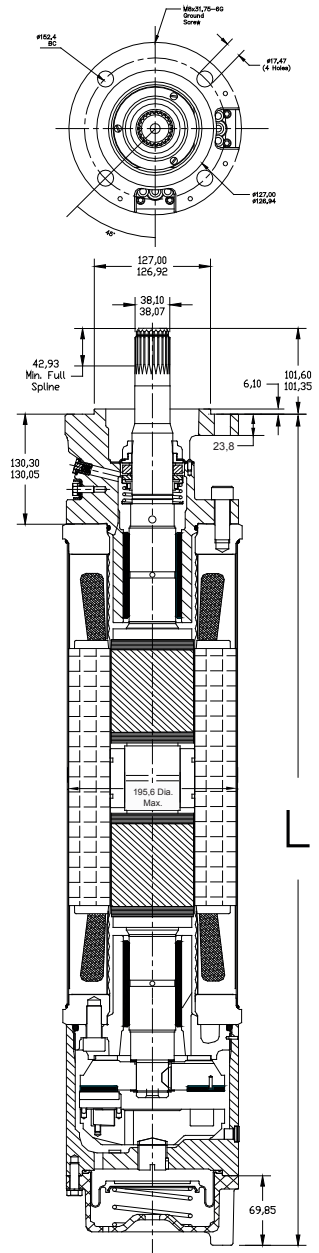
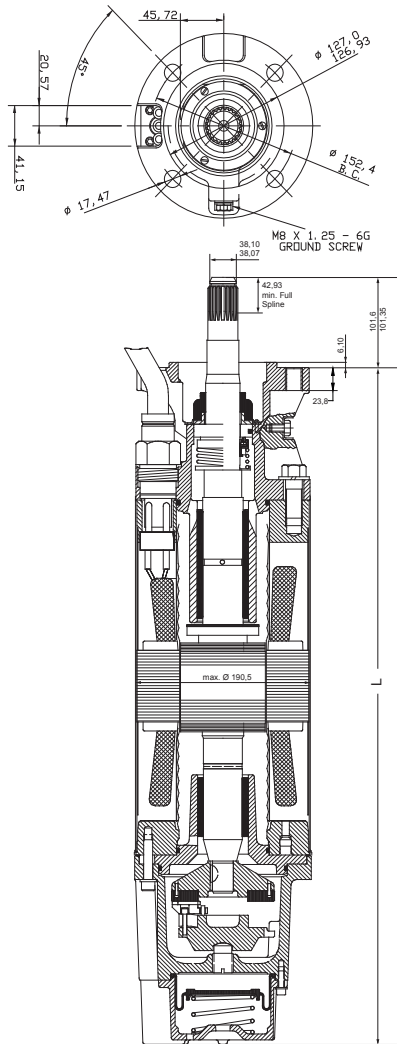
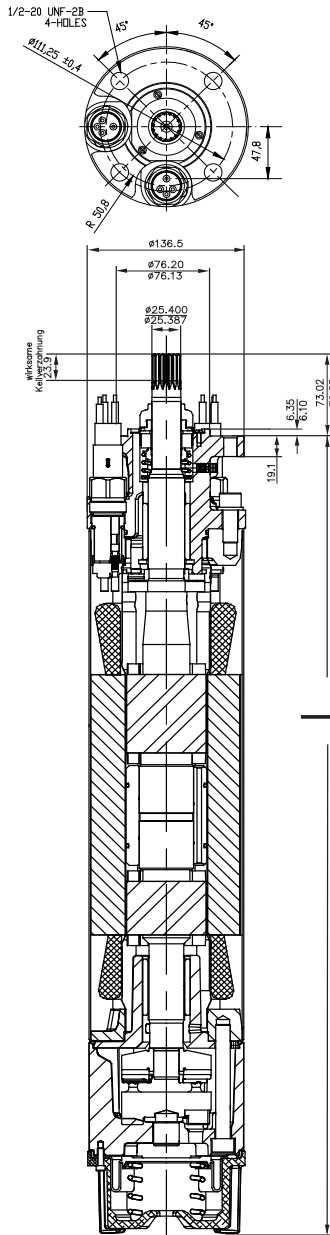

P _N [kW]	L [mm]	Motor Package Size [mm]	Shipping Weight [kg]
3.7	670,5	190,5 x 273,5 x 876,3	55
5.5	735,5		61
7.5	800,6		68
11	866		73
15	931		81
18.5	1061		94
22	1429	222,2 x 273,5 x 1822,4	138
30	1581,6		152

P _N [kW]	L [mm]	Motor Package Size [mm]	Shipping Weight [kg]
30	925	228 x 430 x 1308	145
37	1000		157
45	1077		172
55	1264		227
75	1455		265
93	1748		318
110	1976		381
130	2179		420
150	2408		494

P _N [kW]	L [mm]	Motor Package Size [mm]	Shipping Weight [kg]
30	1138	432 x 245 x 1295	182
37	1265		207
45	1455		252
55	1747		318
75	1976		382
93	2179		421
110	2408		473



FEE - NO.: _____

VISIT DATE: _____

Motor Test Report

Additional comments under "Remarks"

1. CUSTOMER / USER			
Company: _____	Country: _____	Town: _____	
Talked To: _____	Tel.: _____	Assembler: _____	
2. MOTOR			
Model-Nb.: _____	Rating [kW]: _____	Voltage [V]: _____	Hz: _____
Date Code: _____	Sequenz-Nb.: _____	Stator- Nb.: _____	Material: _____
Built in: _____	Equipped for: _____	Worked with: _____	
Worked for: <input type="checkbox"/> Month: _____	<input type="checkbox"/> Days: _____	<input type="checkbox"/> Hours: _____	<input type="checkbox"/> Date failed: _____
3. INSTALLATION			
<input type="checkbox"/> Vertical	<input type="checkbox"/> Horizontal	Pump Make: _____	Type: _____
Well depth [m]: _____	Well diameter [cm]: _____	Pump at [m]: _____	Water inlet at [m]: _____
Cable lenght [m]: _____	Cable square[m]: _____	Protection make: _____	Type: _____
Water: _____	Temperature: _____	PH-Value: _____	Setting [A]: _____
4. EXTERNAL MEASUREMENTS			
Shaft high: _____	Upper End Bell: _____	Shaft Rotation: _____	Slinger: _____
Stator Shell: _____	Lower End Bell: _____	Deposits: _____	Valve: _____
Splines: _____	Diaphragm Pos.: _____	Lead Insul.: _____	Connector: _____
Nameplate: _____	Leakage: _____	Lead Clamp: _____	Hi-Pot: _____
Lead Sealing: _____	Plug Resin: _____		
5. ELECTRICAL MEASUREMENTS			
Phase 1 [Ω]: _____	Phase 2 [Ω]: _____	Phase 3 [Ω]: _____	
Mainphase [Ω]: _____	Startphase [Ω]: _____	Insulation Resist. [MΩ]: _____	
6. TEARDOWN			
Prong: _____	Windings: _____	Winding Splicing: _____	
Filling Liquid: _____	Diaphragm: _____	Segments: _____	
Thrust Bearing: _____	Lower Radial Bearing: _____	Upper Radial Bearing: _____	
Sleeve Lower Shaft End : _____	Sleeve Upper Shaft End : _____	Up-Thrust Bearing: _____	
Shaft Seal : _____	Liner : _____	Rotor Core PM: _____	
Stator Endring : _____	Cage Thrust Bearing : _____	Pressure Test Line : _____	
Pressure Test Stator PU : _____			
7. CONTROL BOX			
Control Box Type: _____	Defective: _____		
8. REMARKS			
Tech. Warranty : _____	Com. Warranty: _____	<input type="checkbox"/> Repair	<input type="checkbox"/> Scrap
Defect: _____		Cause: _____	
Signature: _____	Date: _____	Entered into EDP: _____	Date: _____



maximum lengths in meters for 400V / 50Hz and 3% voltage drop at 50°C ambient temperature and 90°C at copper wire																			
Jacketed Drop Cable Length																			
DOL - Delta start																			
rating		cable size mm ² , copper wire - 90°C rated insulation																	
KW	HP	2,5	4	6	8,4	10	16	25	35	50	70	95	120	150	185	240	300	400	500
4	5,5	95	155	230	325	385	605	915											
5,5	7,5	70	110	170	235	280	440	670	915										
7,5	10	50	80	126	175	205	325	500	685	935									
9,3	12,5	40	65	100	145	170	270	410	565	770	1030								
11	15		55	85	120	140	225	345	470	645	865	1110							
13	17,5		50	75	105	125	195	300	410	560	750	965							
15	20		40	65	90	105	170	265	360	495	665	855	1030						
18,5	25			50	75	85	140	210	290	400	530	680	810	950					
22	30				64	75	120	180	250	340	455	585	700	815	945				
26	35					60	100	150	210	290	385	500	600	705	815	970			
30	40						85	135	185	250	335	430	515	600	695	820	935		
37	50							105	150	205	270	350	420	485	565	665	760	875	980
45	60							90	125	175	235	310	375	445	520	630	730	860	980
52	70							80	110	155	210	270	325	385	450	540	625	735	840
55	75								105	145	195	255	305	360	420	505	580	685	770
60	80								95	135	185	240	290	345	400	485	560	660	750
67	90									120	160	210	255	300	350	415	480	565	640
75	100									105	145	185	225	270	315	375	435	510	580
83	111									95	130	170	210	250	290	350	405	480	540
85	114										125	160	195	230	265	315	365	425	480
93	125										115	150	185	215	255	300	350	410	460
110	150											120	145	170	200	235	270	310	350
130	175												130	155	180	215	250	290	330
150	200													145	170	205	235	275	280
185	250															140	160	185	210
220	300															130	150	175	200
250	335																125	145	160
300	400																		150
350	470																		120
400	540																		

Wye - Delta start																			
rating		cable size mm ² , copper wire - 90°C rated insulation																	
KW	HP	2,5	4	6	8,4	10	16	25	35	50	70	95	120	150	185	240	300	400	500
4	5,5	145	230	350	485	575	900												
5,5	7,5	106	170	250	350	420	660	1010											
7,5	10	75	125	185	260	310	490	750	1025										
9,3	12,5	60	100	155	215	255	405	620	845	1160									
11	15	50	85	130	180	210	340	520	715	980									
13	17,5	45	75	110	155	185	295	450	615	845	1125								
15	20	40	65	95	135	160	260	395	540	740	995								
18,5	25	30	50	80	110	130	210	320	435	600	800	1025							
22	30		45	65	95	110	180	275	375	510	685	875	1050						
26	35		35	55	80	95	150	230	315	435	580	750	900	1055					
30	40			50	70	80	130	200	275	375	500	645	775	905	1045				
37	50				55	65	105	160	220	305	410	525	625	730	845	1000			
45	60					55	90	135	190	260	355	460	560	665	780	945	1095		
52	70					50	80	120	165	230	310	405	490	580	680	815	940		
55	75						75	115	155	220	295	380	460	545	635	760	875	1025	
60	80						70	105	145	205	275	360	435	510	605	725	840	990	1130
67	90						60	95	130	180	240	315	380	450	525	625	720	845	960
75	100							85	115	160	215	280	340	405	470	565	655	765	875
83	111							75	105	145	200	260	315	375	435	525	610	715	820
85	114							70	100	135	185	240	290	345	400	475	550	640	725
93	125							65	95	130	175	230	275	325	380	455	525	615	695
110	150									105	140	180	220	255	300	355	405	465	525
130	175									95	125	160	195	230	270	325	375	435	495
150	200										105	140	170	200	230	275	320	400	420
185	250											110	130	155	180	210	240	280	315
220	300												115	140	160	195	225	260	300
250	335													105	125	140	170	220	250
300	400														110	125	150	175	205
350	470															125	145	170	190
400	540															110	130	150	170

The voltage drop losses in the cable cross-section has a linear uniformity and can easily be converted from 3% to the respective voltage drop losses and the resulting length. An example: 45 KW motor DOL with cable cross section 25mm² has a max. cable length of 90 meters. What length can be achieved up to 5% voltage drop losses? Calculation: Length 90 m / 3 (%) x 5 (%) = 150 m