

CONA®-control Monitoring system for steam traps

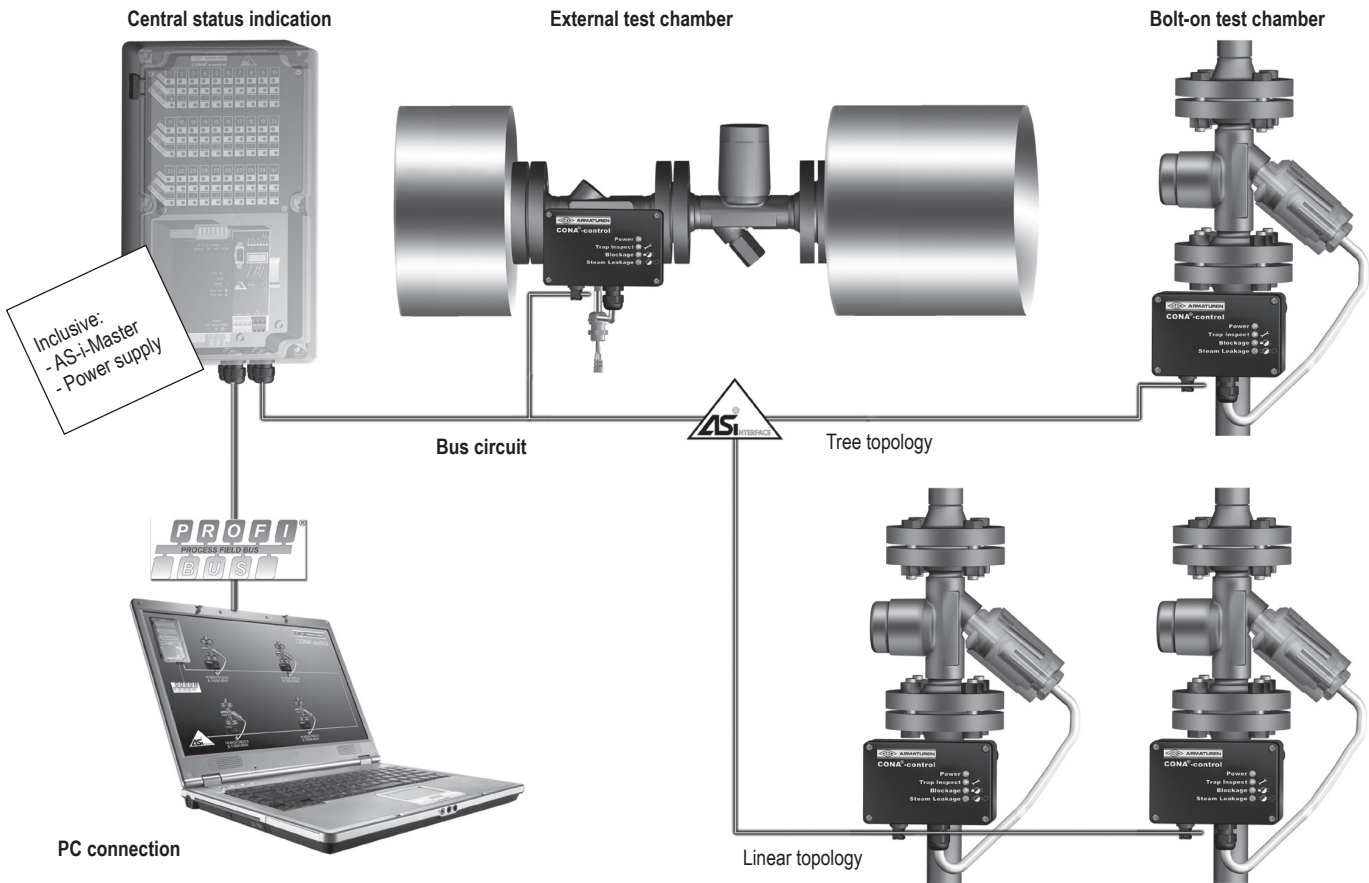

External test chamber

- with flanges (Fig. 685....1)
- with screwed sockets (Fig. 685....2)
- with socket weld ends (Fig. 685....3)
- with butt weld ends (Fig. 685....4)

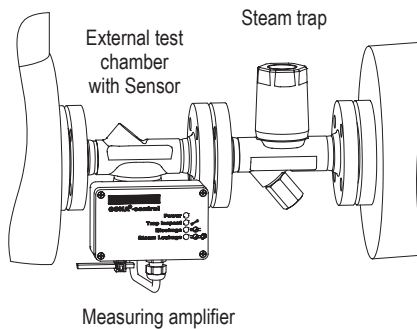

Bolt-on test chamber (as option for ARI-CONA®)

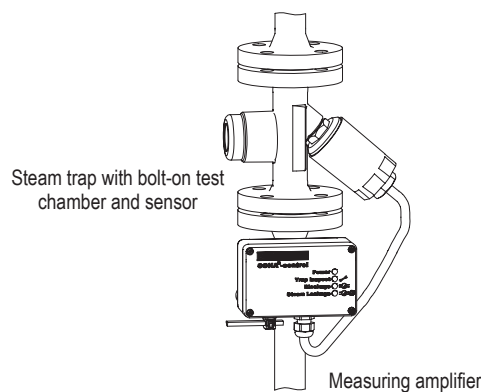

Features:

- Identification of failed steam traps
 - Leaking steam trap (energy wastage)
 - Blocked steam traps (poor plant performance)
- Patent applied, safe temperature sensor
- Local indication of maintenance requirement
- Continuous monitoring of trap performance for instant indication of failure
- External chamber and sensor may be used on all types and makes of steam trap
- Network compatible by AS-i-Bus linking of chambers and sensors (optional)
- Single operation with relay outputs (optional)
- AS-i-Bus gives the opportunity for visual display (optional)

Measuring amplifier

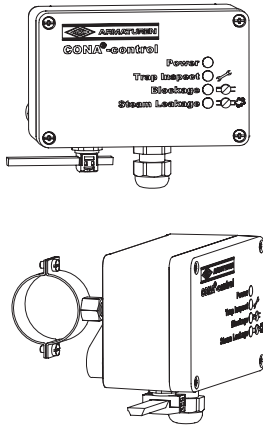

- Indication of operating status for the supervising steam traps by LED's
- Adjustable category temperature for „Blockage“ indication
- AS-i-bus system option (necessary for connection to the central status indication)
- optionally single operation with relay outputs (evaluation e.g. over SPS possible)
- Measuring amplifier required for each test chamber
- Maybe wall or panel mounted
- Maximum distance to the sensor approx. 1m

Technical data	
Ambient temperature:	0 up to +70°C
Supply voltage:	18-36VDC or by AS-i-Bus
Dimensions of body (HxWxD):	75 x 125 x 60mm
Body material:	Aluminium
Enclosure:	IP65
Current consumption:	<100mA

Power supply

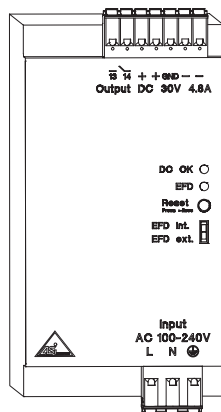

- AS-i-Bus compatible
- Built-in appliance for mounting on a profile in the control cabinet

Technical data	
Supply voltage:	100 V AC - 240V AC 45-65Hz
Output voltage:	30V DC
Ambient temperature:	-25 up to +70°C
Input fuse:	5 A slow fuse
Output current:	4,8 A
Enclosure:	IP20
Current consumption:	approx. 2,1 A (120V AC) / 1A (230V AC)
Weight:	0,9 kg

Central status indication

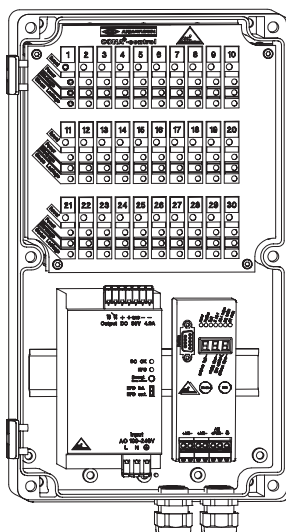

- Central status indication of up to 30 steam traps
- Connection of measuring amplifier by AS-i-Bus
- Integrated AS-i-Master/Gateway
- Integrated power supply for AS-i-Bus system
- One indication card necessary for each measuring amplifier

Technical data	
Internal Bus-system for steam traps:	AS-i-Bus
Interface for superior systems:	Profibus DP other Bus systems on request
Ambient temperature:	0 to +50°C
Supply voltage:	100-240V~ optional: 24V~
Dimensions of body (HxWxD):	360 x 200 x 160mm
Body material:	PC/ABS
Enclosure:	IP65

Indication card

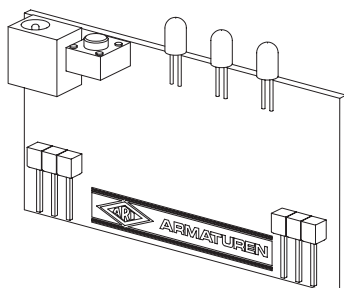

- Indication card for the central status indication
- Indication of operation standards „Blockage“ and „Steam Leakage“ of the connected steam traps by AS-i-Bus
- Reset button for one or all error messages

External test chamber (Forged steel, Stainless steel)

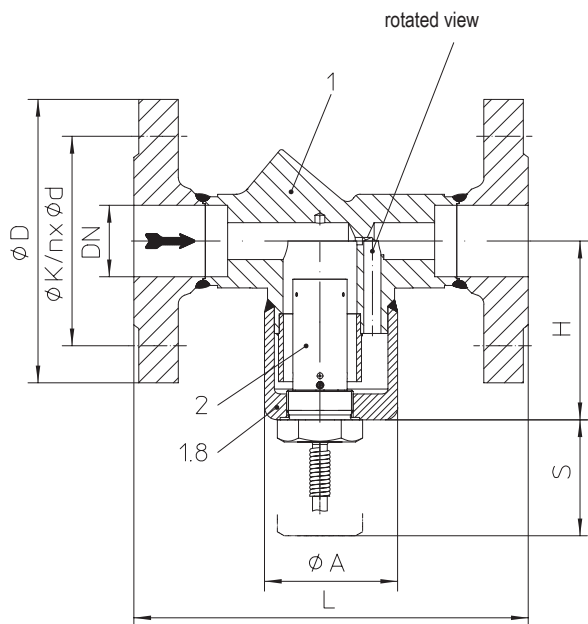

Fig. 685...1 with flanges

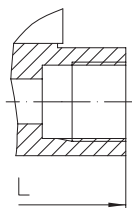

Fig. 685...2 with screwed sockets

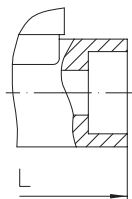

Fig. 685...3 with socket weld ends

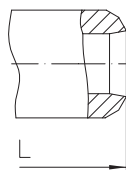

Fig. 685...4 with butt weld ends

- Installation directly in front of the steam trap
- Patent applied, integrated temperature sensor
- Installation position: horizontal, cap downwards!
- Applicable for ball float steam traps CONA S/SC, steam traps of other manufacturers or if a steam trap with screen is necessary

Operating limits

Fig. 45.685	PN40 - 1.0460
Operating pressure PS (bar-g)	32
Operating temperature TS (°C)	250

Fig. 55.685	PN40 - 1.4541
Operating pressure PS (bar-g)	32
Operating temperature TS (°C)	250

Types of connection

Flanges1	DIN PN40
Screwed sockets2	Rp- and NPT-thread
Socket weld ends3	
Butt weld ends4	
Other types of connection on request.	
For ANSI versions refer to data sheet CONA®control-ANSI	

Dimensions and weights		Types of connection								
		Flanges			Screwed sockets Socket weld ends			Butt weld ends		
Nominal diameter	(mm) (inch)	15 1/2	20 3/4	25 1	15 1/2	20 3/4	25 1	15 1/2	20 3/4	25 1
L*	(mm)	150	150	160	95	95	95	250	250	250
H	(mm)	73	73	73	73	73	76	73	73	73
S	(mm)	60	60	60	60	60	60	60	60	60
SQR	(mm)	54	54	54	54	54	54	54	54	54
Ø D	(mm)	95	105	115	--	--	--	--	--	--
Ø K	(mm)	65	75	85	--	--	--	--	--	--
n x Ø d	(n x mm)	4 x 14	4 x 14	4 x 14	--	--	--	--	--	--
Weight approx.	(kg)	3,2	3,2	4,2	1,7	1,6	2,1	2,2	2,3	2,4

* Face-to-face acc. to data sheet resp. customer request

Parts

Pos.	Description	Fig. 45.685	Fig. 55.685
1	Body	P250GH, 1.0460	X6CrNiTi18-10, 1.4541
1.8	Screwed cap sensor	X6CrNiTi18-10, 1.4541	X6CrNiTi18-10, 1.4541
2	Sensor, cpl. *	X6CrNiMoTi17-12-2, 1.4571	X6CrNiMoTi17-12-2, 1.4571

* Spare part

Information / restriction of technical rules need to be observed!

Operating instructions can be ordered by phone +49 (0)5207 / 994-0 or fax +49 (0)5207 / 994-158 or -159.

External test chamber (Forged steel, Stainless steel)

- Installation directly in front of the steam trap
- Patent applied, integrated temperature sensor
- Installation position: horizontal, cap downwards!
- Applicable for ball float steam traps CONA S/SC, steam traps of other manufacturers or if a steam trap with screen is necessary

Operating limits

Fig. 45.685	PN40 - 1.0460
Operating pressure PS (bar-g)	32
Operating temperature TS (°C)	250

Fig. 55.685	PN40 - 1.4541
Operating pressure PS (bar-g)	32
Operating temperature TS (°C)	250

Types of connection

Flanges1	PN40 acc. to DIN2501
Screwed sockets2	Rp- and NPT-thread acc. to DIN EN 10226-1
Socket weld ends3	acc. to DIN EN 12760
Butt weld ends4	acc. to DIN EN 12627

Other types of connection on request.

For ANSI versions refer to data sheet CONA®control-ANSI

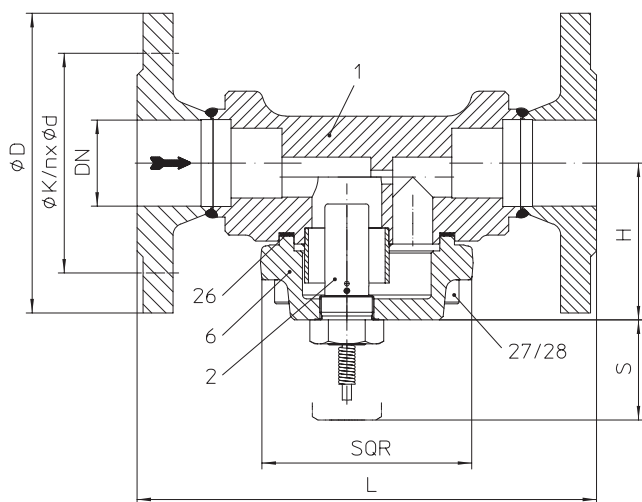

Fig. 685....1 with flanges

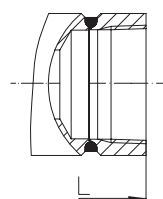

Fig. 685....2 with screwed sockets

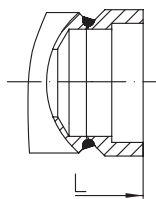

Fig. 685....3 with socket weld ends

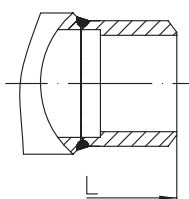

Fig. 685....4 with butt weld ends

Dimensions and weights		Types of connection					
		Flanges		Screwed sockets Socket weld ends		Butt weld ends	
Nominal diameter	(mm) (inch)	40 1 1/2	50 2	40 1 1/2	50 2	40 1 1/2	50 2
L*	(mm)	230	230	on request			
H	(mm)	78,5	78,5				
S	(mm)	60	60				
SQR	(mm)	105	105				
Ø D	(mm)	150	165				
Ø K	(mm)	110	125				
n x Ø d	(n x mm)	4 x 18	4 x 18				
Weight approx.	(kg)	9,8	11,2				

* Face-to-face acc. to data sheet resp. customer request

Parts

Pos.	Description	Fig. 45.685	Fig. 55.685
1	Body	P250GH, 1.0460	X6CrNiTi18-10, 1.4541
2	Sensor, cpl. *	X6CrNiMoTi17-12-2, 1.4571	X6CrNiMoTi17-12-2, 1.4571
6	Cover Sensor	P250GH, 1.0460	X6CrNiTi18-10, 1.4541
26	Sealing ring *	Graphite (CrNi laminated with graphite)	
27	Cheese head screw	21CrMoV 5-7, 1.7709	
28	Hexagonal nut	21CrMoV 5-7, 1.7709	

* Spare part

Information / restriction of technical rules need to be observed!

Operating instructions can be ordered by phone +49 (0)5207 / 994-0 or fax +49 (0)5207 / 994-158 or -159.

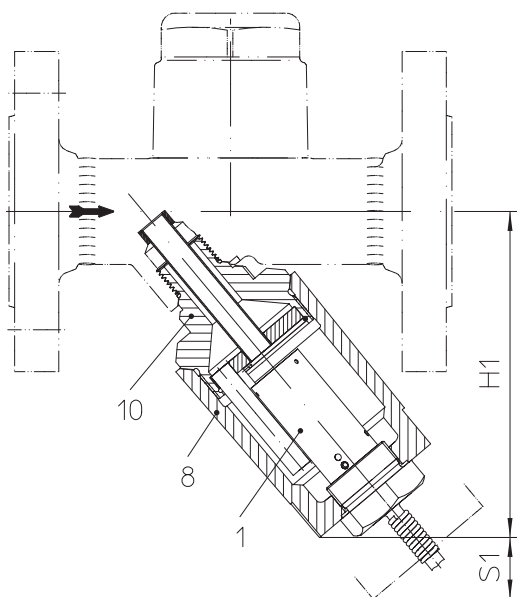
Bolt-on test chamber (Forged steel, Stainless steel)

- Suitable for horizontal or vertical installation position of the steam traps;
Test chamber diagonally downwards!
- Patent applied, integrated temperature sensor
- Applicable for CONA B (Fig. 601) and CONA M (Fig. 612) with Y-body DN15-25 (design of the steam traps see corresponding data sheets)

Operating limits

Options: Bolt-on test chamber	PN40 - 1.0460
Operating pressure PS (bar-g)	32
Operating temperature TS (°C)	250

Options: Bolt-on test chamber	PN40 - 1.4541
Operating pressure PS (bar-g)	32
Operating temperature TS (°C)	250

Connection external test chamber

Connection	Thread M20 x 1,5 (for CONA steam traps)
------------	---

For ANSI versions refer to data sheet CONA®control-ANSI

Dimensions and weights		Connection
Size	(mm)	Thread M20 x 1,5
H1	(mm)	117
S1	(mm)	25
Weight approx.	(kg)	1,2

Dimensions and weights of the CONA®-steam traps see corresponding data sheet

Parts

Pos.	Description	Options: Bolt-on test chamber	
1	Sensor, cpl. *	X6CrNiMoTi17-12-2, 1.4571	X6CrNiMoTi17-12-2, 1.4571
8	Screwed cap sensor	P250GH, 1.0460	X6CrNiTi18-10, 1.4541
10	Socket	X6CrNiMoTi17-12-2, 1.4571	X6CrNiMoTi17-12-2, 1.4571

* Spare part

Information / restriction of technical rules need to be observed!

Operating instructions can be ordered by phone +49 (0)5207 / 994-0 or fax +49 (0)5207 / 994-158 or -159.

Operation with central status indication

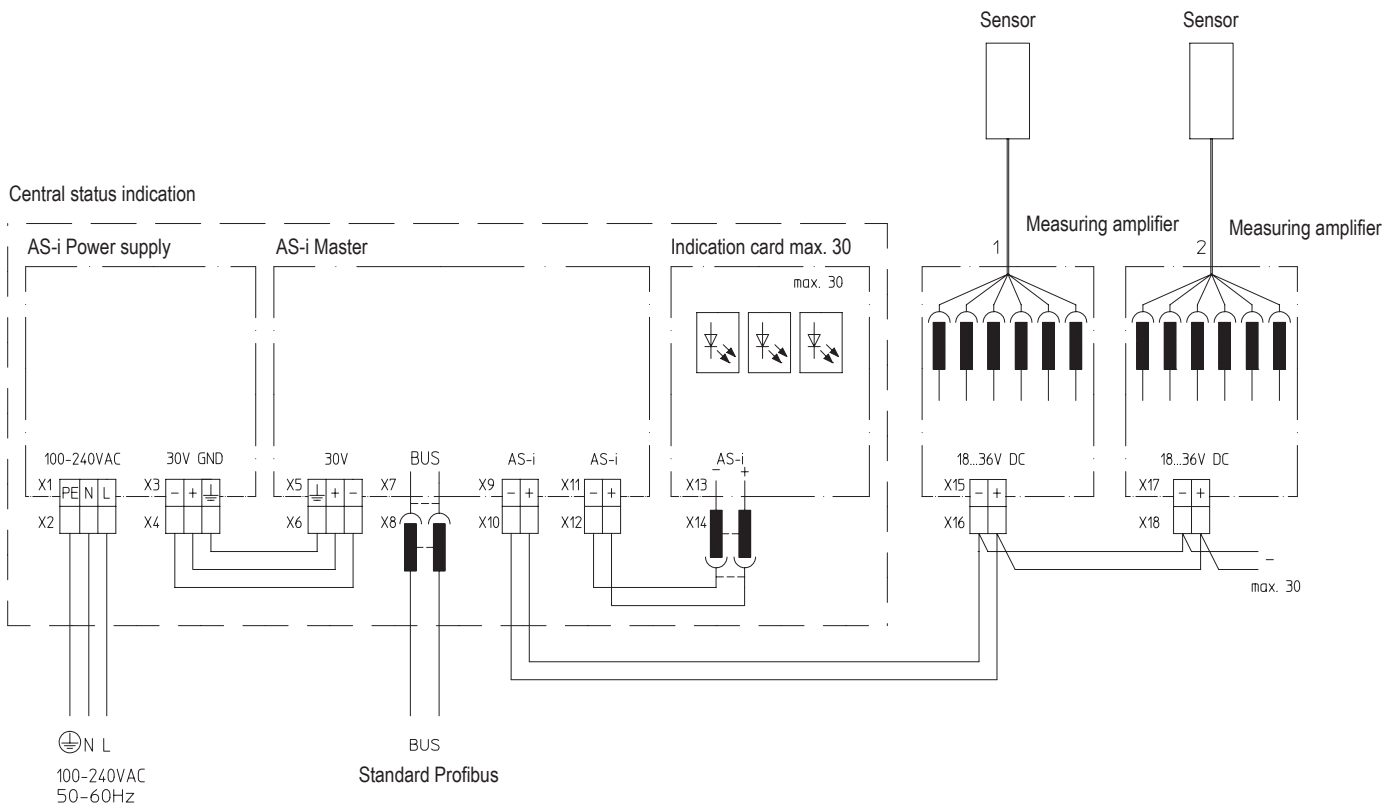

Single operation without central status indication

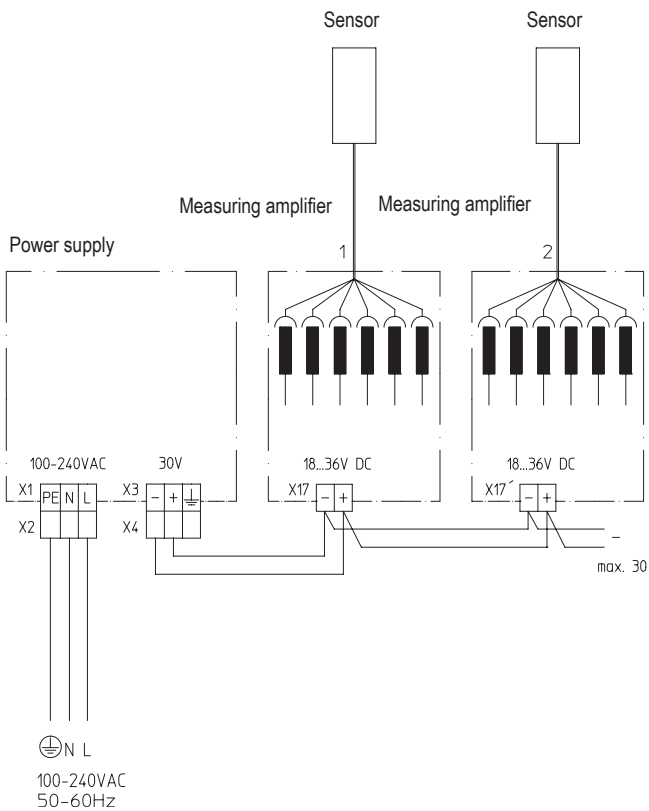

Single operation without central status indication with relay outputs

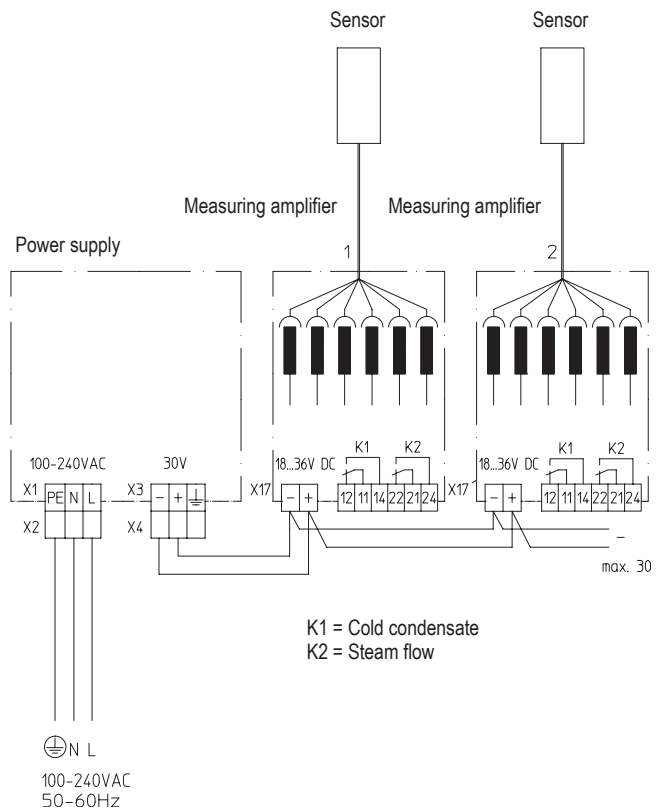

Illustration of test chamber and steam trap	LED indication at the measuring amplifier - Indication by Bus	Operating status
	<ul style="list-style-type: none"> <input type="radio"/> Trap Inspect * <input checked="" type="radio"/> Blockage <input checked="" type="radio"/> Steam Leakage 	<p>System/steam trap not in operation Sensor in cold air/steam and the temperature is below the specified temperature</p>
	<ul style="list-style-type: none"> <input type="radio"/> Trap Inspect * <input type="radio"/> Blockage <input type="radio"/> Steam Leakage 	<p>Steam traps works correct Sensor in hot condensate</p>
	<ul style="list-style-type: none"> <input checked="" type="radio"/> Trap Inspect * <input type="radio"/> Blockage <input checked="" type="radio"/> Steam Leakage 	<p>Steam leakage Sensor in steam and the temperature is above the specified temperature</p>
	<ul style="list-style-type: none"> <input checked="" type="radio"/> Trap Inspect * <input checked="" type="radio"/> Blockage <input type="radio"/> Steam Leakage 	<p>Blocked steam trap Sensor in cold condensate, the condensate is below the specified temperature</p>

* When using the „Central status indication“ the error will be saved and the LED „Trap Inspect“ is blinking.

